

YAMAHA

ELECTRONIC PIANO

CP35

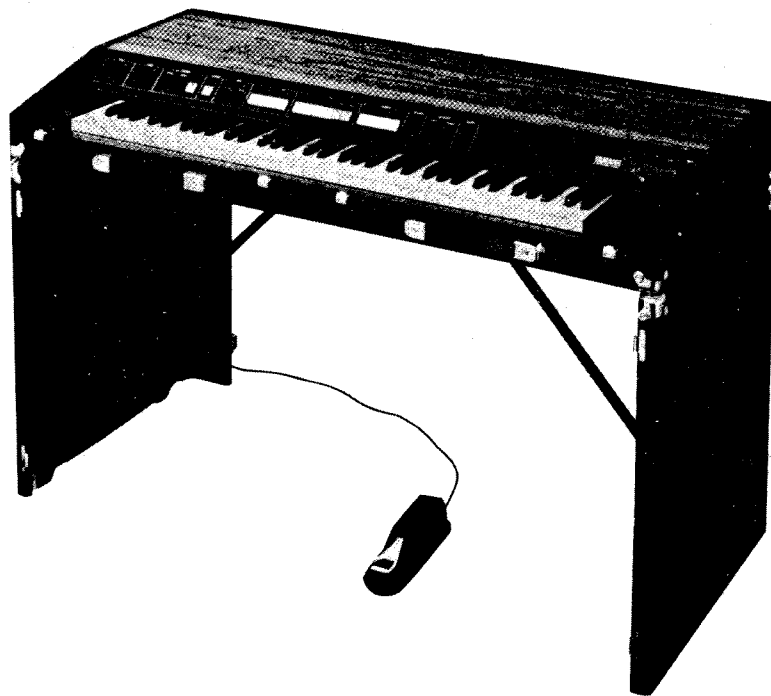

SERVICE MANUAL

CONTENTS

	CODING GUIDE	1
	SPECIFICATIONS	2
	ASSEMBLY PROCEDURE	3
	DISASSEMBLY PROCEDURE	4
	PANEL LAYOUT	6
	PART NAMES AND FUNCTIONS	7
	BLOCK DIAGRAM	9
	TECHNICAL EXPLANATION	10
	ADJUSTING THE MECHANISM	18
	BASIC ADJUSTMENT PROCEDURE (ELECTRICAL)	19
	IC DATA CHART	21
DM	Circuit Board & Wiring	23
DM	Circuit Diagram	24
FL	Circuit Board & Wiring	25
FL	Circuit Diagram	26
PN2, PN3	Circuit Board & Wiring	27
PN2, PN3	Circuit Diagram	28
EFT	Circuit Board & Wiring	29
EFT	Circuit Diagram	30
PN1, PN4	Circuit Board & Wiring	31
PN1, PN4	Circuit Diagram	32
MK1, MK2, MK3	Circuit Board & Wiring, Circuit Diagram	33
JK1, JK2, JK3, AC	Circuit Board & Wiring, Circuit Diagram	34
DC	Circuit Board & Wiring, Circuit Diagram	35
	PARTS LIST	

CODING GUIDE

1 Wiring Notation

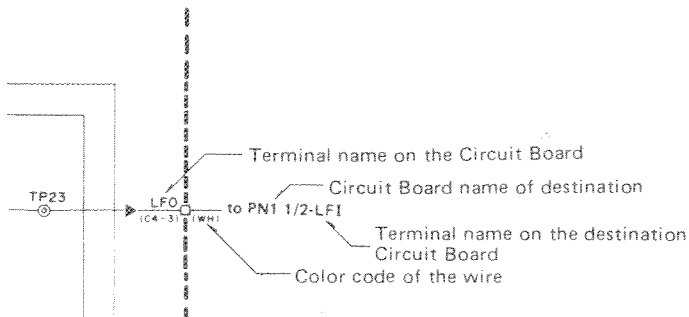

Note: Types of wire

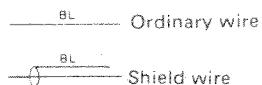

2 Symbol Description

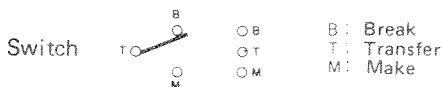
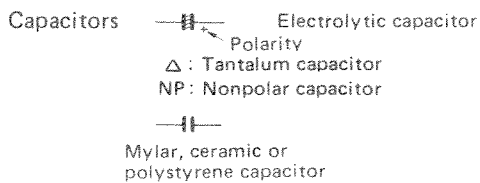
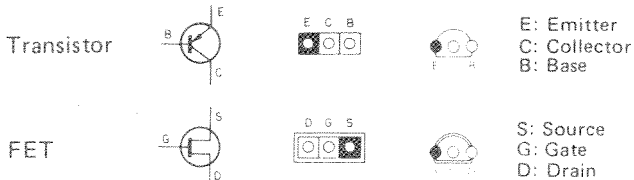

3 Abbreviations of Wire Color Codes

BLACK (クロ).....BL	BROWN (チャ).....BR	RED (アカ).....RE
ORANGE (タイ).....OR	YELLOW (キイ).....YE	GREEN (ミト).....GR
BLUE (アオ).....BE	VIOLET (ムラ).....VI	GRAY (ハイ).....GY
WHITE (シロ).....WH	GRASS GREEN (クサ).....GG	SKY BLUE (ソラ).....SB
PINK (モモ).....PK	TRANSPARENT (トウメイ).....TR	

4 Relation of Color Coding and Notes

C	C≠	D	D≠	E	F	F≠	G	G≠	A	A≠	B
BR	RE	OR	YE	GR	BE	VI	GY	WH	GG	SB	PK
(チャ)	(アカ)	(タイ)	(キイ)	(ミト)	(アオ)	(ムラ)	(ハイ)	(シロ)	(クサ)	(ソラ)	(モモ)

5 Logic Symbols

	MIL	YAMAHA
NOT		
NOR		
NAND		

Exclusive OR (排他的論理和)

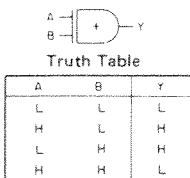

NOT (Inverter)

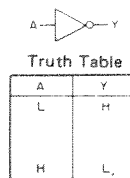

OR

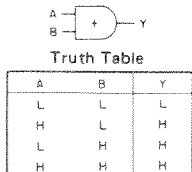

NOR

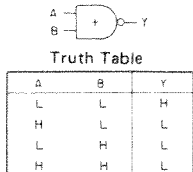

AND

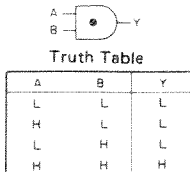

NAND

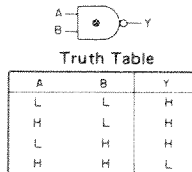

SPECIFICATIONS

KEYBOARD 73 keys (E0 – E6)
 Velocity-sensitive touch response
 16 note simultaneous output,
 max.

CONTROLS
 PITCH I
 PITCH II
 DECAY I 8 position switch
 DECAY II 8 position switch
 TREMOLO SPEED
 TREMOLO DEPTH
 TREMOLO ON/OFF
 FLANGER ON/OFF
 WAVE I 4 position switch (A,B,C,D)
 WAVE II 4 position switch (A,B,C,D)
 FILTER I 4 independent selectors
 (1,2,3,4)
 FILTER II 4 independent selectors
 (1,2,3,4)
 5TH, 8TH Independent 5th and 8th
 transpose selectors
 PRESETS 4 independent selectors
 (1,2,3,4)
 BALANCE I ↔ II
 EQUALIZER Continuously variable bass and
 treble controls

VOLUME

SIDE PANEL

KEY CODE OUTPUT
 FOOT SW TREMOLO
 FOOT SW SUSTAIN
 BALANCED XLR type connectors
 OUTPUT ①②
 UNBALANCED 1/4" phone jacks
 OUTPUT ①②
 PHONES 8 ohms or high impedance
 headphones

LINE ON/OFF

POWER REQUIRE- U.S. & Canadian models
MENTS 120V 50/60Hz 36 Watts
 General model
 Selectable (100, 120, 220 or
 240V) 36 Watts

DIMENSIONS 50-1/4" x 31-1/4" x 23-1/2"
 (W x H x D)
 (1,276 x 794 x 596 mm)

WEIGHT 110.2 lbs (50 kg)

STANDARD FC-4 footswitch

ACCESSORY

** Specifications are subject to change without notice.*

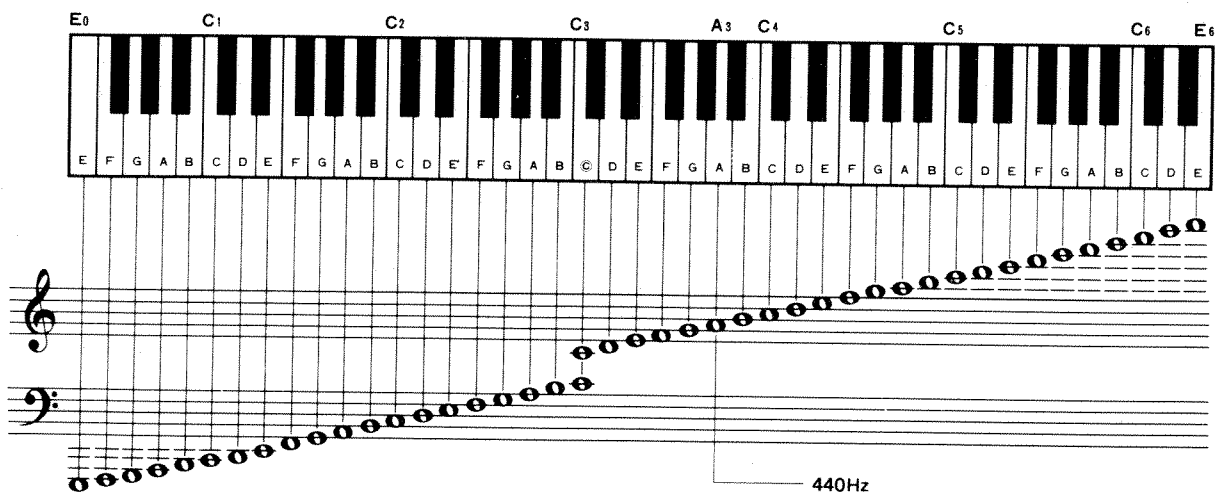

ASSEMBLY PROCEDURE

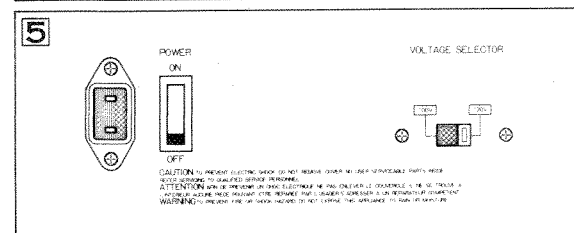
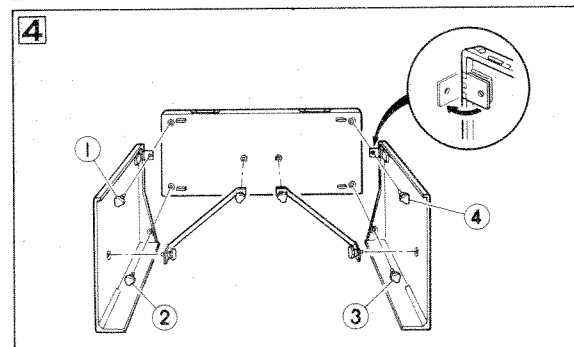
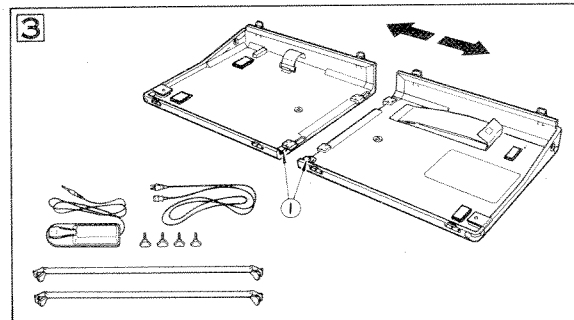
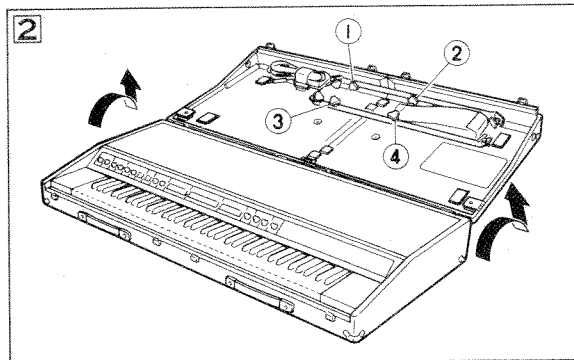
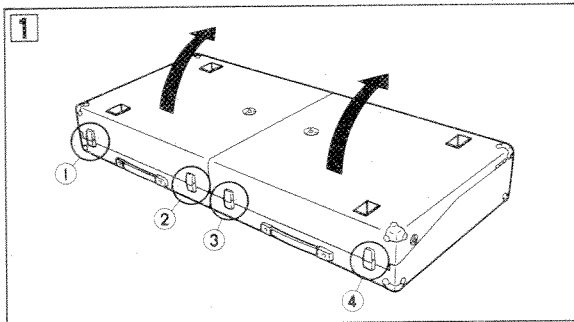

(U.S. & CANADIAN MODELS)

- Lay the CP35 on the floor as shown and open the lid fully by unlatching the four catches ① ~ ④ .

- Detach the lid from the body by lifting it so as to slip it off its rear hinges. Provided inside of the lid are the AC cord, leg braces and the sustain pedal.
- Unscrew the thumbscrews ① ~ ④ and remove the leg braces.
NOTE: Make sure not to lose these thumbscrews, for they will be used when connecting the main body and legs.

- Unlatch the catch ① found inside of the lid and pull the lid apart right and left.
NOTE: The two halves of the lid become the CP35's legs.

- Place the main body of the CP35 on its back edge and fasten one leg to each side of the body using two of the thumbscrews removed in step 2.
- Fix the main body and the legs securely with the leg braces.
- Set the CP35 upright and check each thumbscrew for tightness. This completes the physical assembly of the CP35.
- Connect both the output cord to the amplifier and the sustain pedal.

- Set the voltage selector to the proper line voltage of that area where CP35 is used and set the switches and controls. And then connect the AC cable to the AC INLET jack on the CP35 firmly.
(→ SEE PAGE8)

DISASSEMBLY PROCEDURE

1. Opening the lid

Remove the 4 screws holding the lid.
Grasp the panel just above the keyboard and lift up.

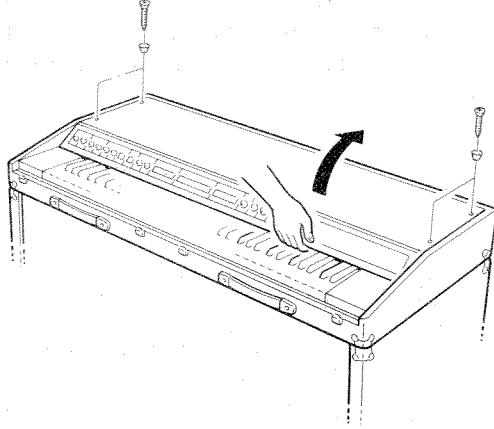

Use the stay provided to hold the lid. The stay provides two different lid angles.

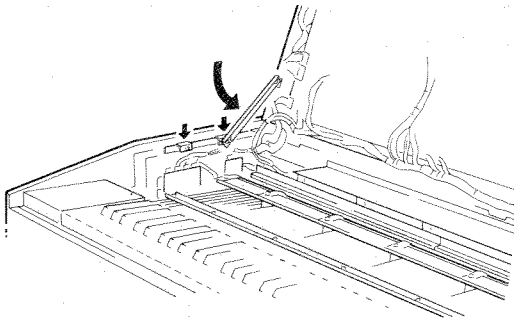

2. Removing circuit boards

Compress the board holders with pliers to release the boards.

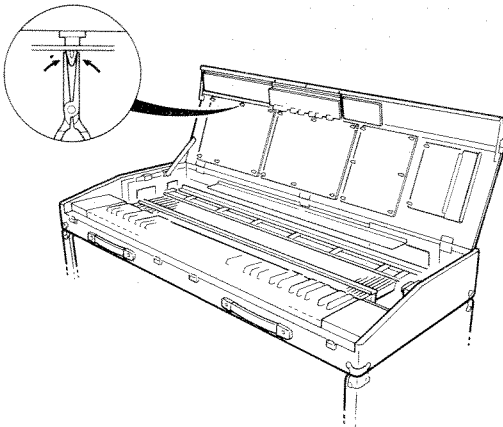

3. Removing panel boards

1) Remove all front panel knobs, hex nuts and washers.
(PN1, PN4 boards)

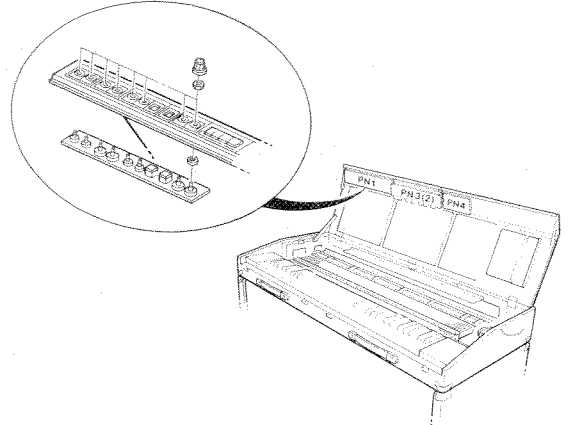

2) Removing the screws on the boards will allow them to be removed one at a time. Compress the PN3 circuit board holders with pliers to release them.
(PN2, PN3)

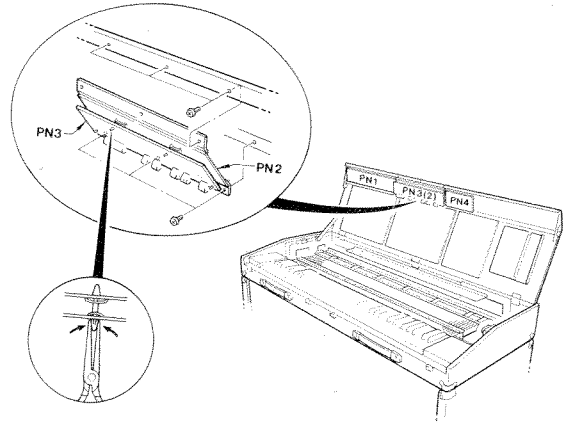

4. Removing the switch assembly (MK board)

Remove the shield plate.

The switch assembly is divided into 3 separate parts. Remove the screws of the desired section or sections to be removed.

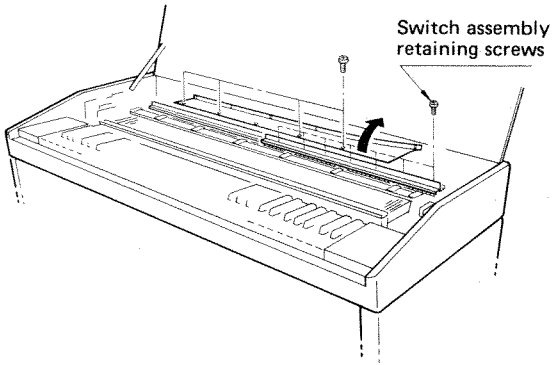

5. Removing the keys

Before removing any keys be sure to remove the switch assembly, being careful not to damage the switch contacts.

Remove the stopper rail and the key stopper screws. Reinforcing hardware is attached to the stopper rail.

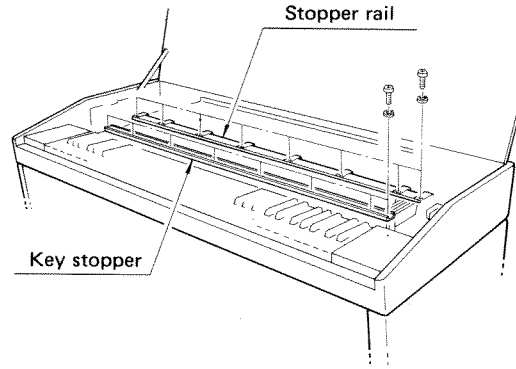

Be sure to remove the black keys before removing the white keys.

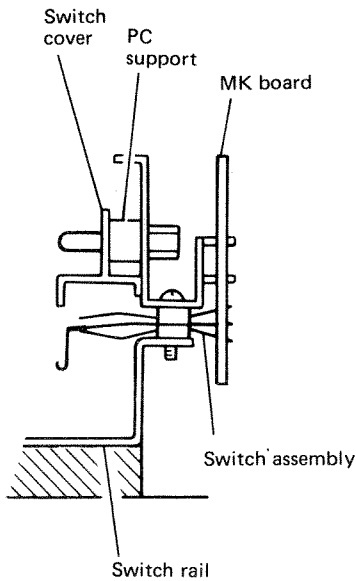
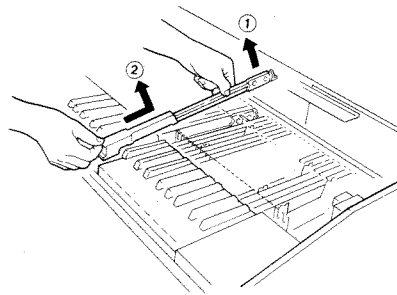
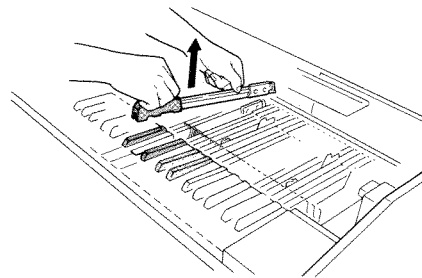

The table below gives the correspondence between output terminals, the notes output, and the output envelopes.

Terminal	Output note	Output envelope
	HS2 43 $E_0 \sim C_1 \quad C_1^\# \sim C_2$	<p>Sustain envelope</p> <p>Approx. 100mV</p> <p>Attack envelope</p> <p>Approx. 50mV</p>
	HS3 42 $C_2^\# \sim C_3$	
	HS4 41 $C_3^\# \sim C_4$	
	HS5 40 $C_4^\# \sim C_5$	
	HS6 39 $C_5^\# \sim E_6$	
	YM722	
	CPB	
	HA2 37 $E_0 \sim C_1 \quad C_1^\# \sim C_2$	
	HA3 36 $C_2^\# \sim C_3$	
	HA4 35 $C_3^\# \sim C_4$	
	HA5 34 $C_4^\# \sim C_5$	
	HA6 33 $C_5^\# \sim E_6$	
C15 15 CIA		
C16 16 CIB		
C15 29 C8B		
C16 30 C8A		

- So that the charge/discharge times of the capacitors which determine the envelopes of the 8 intervals of $C_1 \sim C_{16}$ will not have any effect on the note envelopes, two capacitors are used for each note and are switched alternately in and out.
- The basic waveform that will be used to produce all music signals is selected by the A, B, C and D positions of the **WAVE I, II** (PSW9, 10) switches as shown in the diagram.

WAVE I II

Output waveform

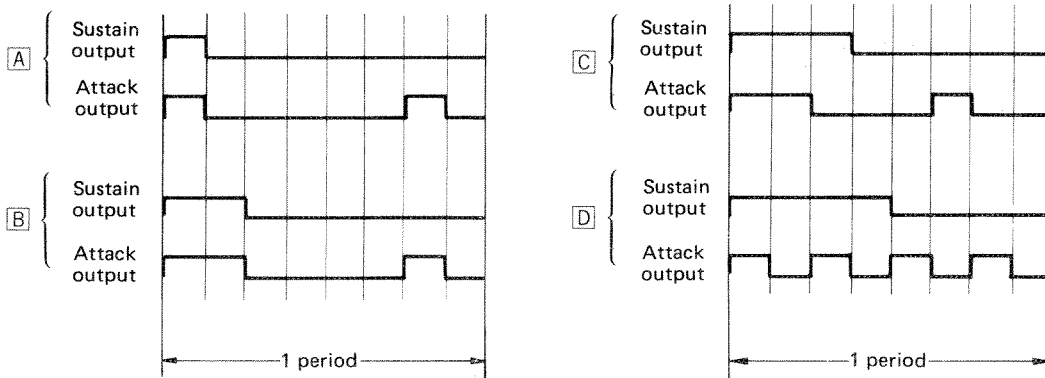

- By using the CH-II 5th and 8th (PSW19, 20) panel switches, the second channel can be shifted up a fifth, an octave, or a twelfth from the first channel.

	SET CONDITION	OUTPUT NOTE RANGE
Channel I		$E_0 \sim A_3 \sim E_6$
Channel II	• 5th On	$B_0 \sim E_4 \sim B_6$ (up a 5th)
	• 8th On	$E_1 \sim A_4 \sim E_7$ (up an octave)
	• 5th, 8th On	$B_1 \sim E_5 \sim B_7$ (up a twelfth)

Filters

The filter circuits are constructed entirely of capacitors, resistors, and Op amps, in both filter and mixer configurations. They combine the attack outputs HA2–HA6 and the sustain outputs HS2–HS6 and send them to the filter select circuit.

Filter select circuit

The select circuit is a Schmidt trigger combining an "On" switch, a NAND and an inverter, plus a flip flop, an indicator LED, and an LED driver with an op amp multivibrator (low-frequency oscillator) for LED flashing. FET gates (FET1–12, one for each voice) are turned on (0V) or off (–15V) to select the voice.

The select switches operate as follows:

- The four voices of the Filter I–1 to I–4 switches may be combined.
- The four voices of the Filter II–1 to II–4 switches may be combined.
- Only one of the Preset 1 to 4 voices may be selected.
- The Presets switches activate pre-selected settings for Wave I, II, 5th, 8th, and Balance.
- When power is first turned on, the Presets I LED lights and the Filter I–1 and Filter II–3 LEDs flash. Playing the keyboard produces the voice selected by Presets 1.
- To switch from the Preset voice to the Filter voice press the lit Preset switch.
- The Filter I or Filter II switch can be depressed in preparation for use while using a Preset voice. The selected switch will flash. In addition, the Wave switch and the Balance control may be preset at this time.
- To switch from the Filter I or II voice to a Preset voice, press the appropriate Preset switch. The selected switch will light, and the previous Filter I or II switch will flash.

The filter select circuit is shown in the diagram. (Refer to the SELECT circuit diagram on page 14)

The power-on reset sequence is as follows:

- Immediately after power on, –15V (V_{DD}) from the 1 μ F capacitor and the 100K resistor sets the Preset I flip flop via pin S of IC16, the Filter I–1 flip flop (1/2 of IC9), and the Filter II–3 flip flop (1/2 of IC12).
- A high appears at pin 16 of the set of Preset 1 flip flop (half of IC16), passes through PR1 and turns on Preset 1 FET 9 gate. The Preset 1 voice goes through FP to the mixing terminal. At the same time, Filter I–1 and Filter II–3 gates FET1–FET7 are on, so the signal also passes through F1 and F2 to the Balance mixing circuit.
- The high at PR1 goes through diode D42 and an inverter (part of IC7) to become a low. The low turns off mixing gate FET1. This shows that the Preset 1 voice is to be given priority regardless of Preset 1, Filter I–1, and Filter I–3.
- The low at MS is inverted by IC7 to become a high, and the AND gate IC14 pin 13 becomes high. Then the Op amp IC15, a capacitor and a resistor form a multivibrator, which sends the waveform shown to pin 12 of AND gate IC14.

Output at pin 11 of the AND gate (IC14) sends a low signal as shown in the timing diagram to turn on transistor Tr1.

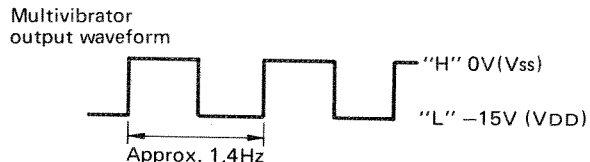

The collector of Tr1 drives the common anode line of **Filter I-1 ~ 4**, **Filter II-1 ~ 4**, **5th** and **8th** indicator LEDs.

This causes **the Filter I-1** and **Filter II-3** LEDs to flash continuously.

e) **5th** and **8th** signals

The high from PR1 (see (b) above) passes through diode D35 to become a high at the **5th** terminal, then passes through D38 to bring the **8th** terminal high. In other words, **the Preset I** voice activated with power on has **5th** and **8th** turned on. Channel II has a pitch that is higher than channel I by an octave and a fifth. The LEDs don't flash after power on.

5th and 8th selected by Presets

PRESETS	1	2	3	4
channel II	5TH & 8TH	5TH & 8TH	Normal	8TH

f) **Wave I** and **Wave II** signals

The high from PR1 (see (b) above) goes to the PR1 terminals on the PN1 board, and sets channel 1WS1 to high and channel II 2WS0 and 2WS1 to high. When Preset 1 is selected, this shows that wave C is selected on channel I and wave D on channel II.

PRESET WAVE selection

PRESETS	1	2	3	4
Channel I	WAVE C	WAVE D	WAVE B	WAVE C
WSO	L	H	H	L
WSI	H	H	L	H
Channel II	WAVE D	WAVE D	WAVE D	WAVE C
WSO	H	H	H	L
WSI	H	H	H	H

g) Diodes D46–D60 are used to select one preset voice and ignore the others. (no mixing performed).

MIXING

Overall timbre of the signal from the output of the filter select and preset select circuits is adjusted by equalization. A simulated semiconductor inductor is formed by IC19-2/2 which, combined with IC20-1/2, forms a peaking type equalizer. This equalizer creates a +10dB frequency boost at 560Hz.

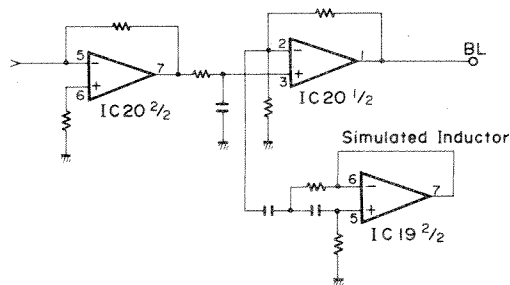

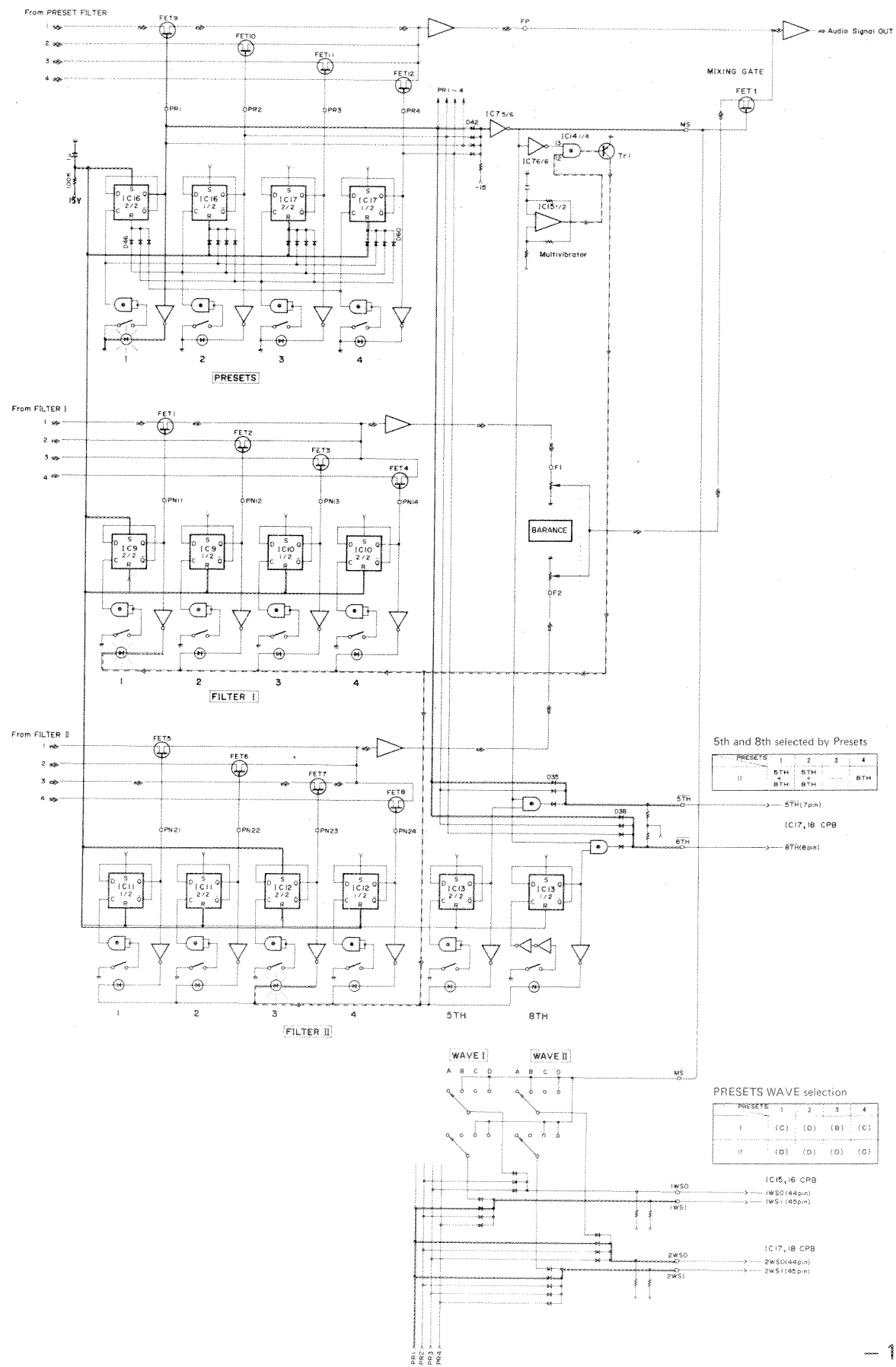

5th and 8th selected by Presets

PRESETS	1	2	3	4
I	5TH	5TH	5TH	5TH
II	8TH	8TH	8TH	8TH

PRESETS WAVE selection

PRESETS	1	2	3	4
I	(C)	(D)	(B)	(C)
II	(D)	(D)	(D)	(C)

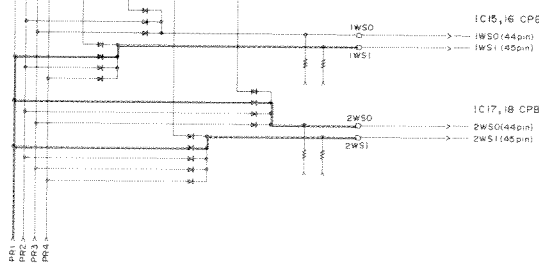

KEY CODE OUT

This output is provided for connection to other keyboards having a KEY CODE INPUT connector, such as the CS70M. A special cable is used to connect the CP-35 KEY CODE OUTPUT to the peripheral keyboard's KEY CODE INPUT. With the CP35 connected to another keyboard in this manner, the CP35 keys directly control on/off switching of the respective keys on the peripheral keyboard.

KEY CODE INTERFACE

The key code interface circuit transforms the 4-bit CPA key code output data into the required parallel key code data format.

CPA OUTPUT KEY CODE DATA FORMAT

Transmitted key code																																																			
Channel	1	2	3	4	5	6	7	8	9	10	11	12	13	14	15	16	17	18	19	20	21	22	23	24	25	26	27	28	29	30	31	32	33	34	35	36	37	38	39	40	41	42	43	44	45	46	47	48			
KC1	BR	B1	N1																																																
KC2	DP	B2	N2																																																
KC3	MK	B3	N3	←			←			←			←			←			←			←			←			←			←			←			←			←			←			←			←		
KC4	☆	CHG	N4																																																
Note timing 16CHs				1			4			7			10			13			16			3			6			9			12			15			2			5			8			11			14		

Key code format (Block)								Key code format (Note)												
B1	H	L	H	L	H	L	H	N1	L	H	L	L	H	L	L	H	L	H	L	
B2	L	H	H	L	L	H	H	N2	L	L	H	L	L	H	L	L	H	L	L	H
B3	L	L	L	H	H	H	H	N3	L	L	L	H	H	H	L	L	L	H	H	H
73 Keys	E ₀	C ₁ [#]	C ₂ [#]	C ₃ [#]	C ₄ [#]	C ₅ [#]	C ₆ [#]	N4	L	L	L	L	L	L	H	H	H	H	H	H
	C ₁	C ₂	C ₃	C ₄	C ₅	C ₆	E ₆		C [#]	D	D [#]	E	F	F [#]	G	G [#]	A	A [#]	B	C

KEY CODE OUT DATA

The format of the parallel key code data output from the key code data interface is as shown below.

Key Code Output Connector													
Pin Name	Pin No.	Data · Condition											
K2	(1)	Keyboard data "L" (fixed)											
K1	(2)	Keyboard data "H" (fixed)					Block data						
		E ₀ ~C ₁	C ₁ [#] ~C ₂	C ₂ [#] ~C ₃	C ₃ [#] ~C ₄	C ₄ [#] ~C ₅	C ₅ [#] ~C ₆	C ₆ [#] ~E ₆					
B3T	(3)	L	L	L	H	H	H	H					
B2T	(4)	L	H	H	L	L	H	H					
R1T	(5)	H	L	H	L	H	L	H					
		C [#]	D	D [#]	E	F	F [#]	G	G [#]	A	A [#]	B	C
N4T	(6)	L	L	L	L	L	L	H	H	H	H	H	
N3T	(7)	L	L	L	H	H	H	L	L	L	H	H	H
N2T	(8)	L	L	H	L	L	H	L	L	H	L	L	H
N1T	(9)	L	H	L	L	H	L	L	H	L	L	H	L
OCT	(16)	Octave data "L" (fixed)											
CON	(17)	Connection data "L" (fixed)											

端子名	端子No.	内容・状態
BRT	(18)	Touch response data "H" when the transfer point (T) is not connected with the break contact (BR), "L" when the transfer point is connected to the break contact.
MKT	(19)	Touch response data "H" when transfer point (T) is connected to the make contact (MK), "L" when envelope has ended and there is no connection with break point (BR).
DPT	(20)	Damp data "H" when the sustain pedal is pressed, "L" when released.
SYT	(21)	Syncro data Synchronization signal. Synchronization=48 microseconds.
CKT	(22)	Clock $\phi M/3$ Synchronized at 1/3 master clock.
Vss	(23)	Power
Vss	(24)	"

KEY CODE DATA OUT TIMING CHART

After power has been turned on, if the A₂ key is first pressed, then while A₂ is held F₃ is pressed, the following timing results.

V_H = +3.4 ±_{0.1} VOLTS

V_{SS} = 0VOLTS

V_{DD} = -15VOLTS

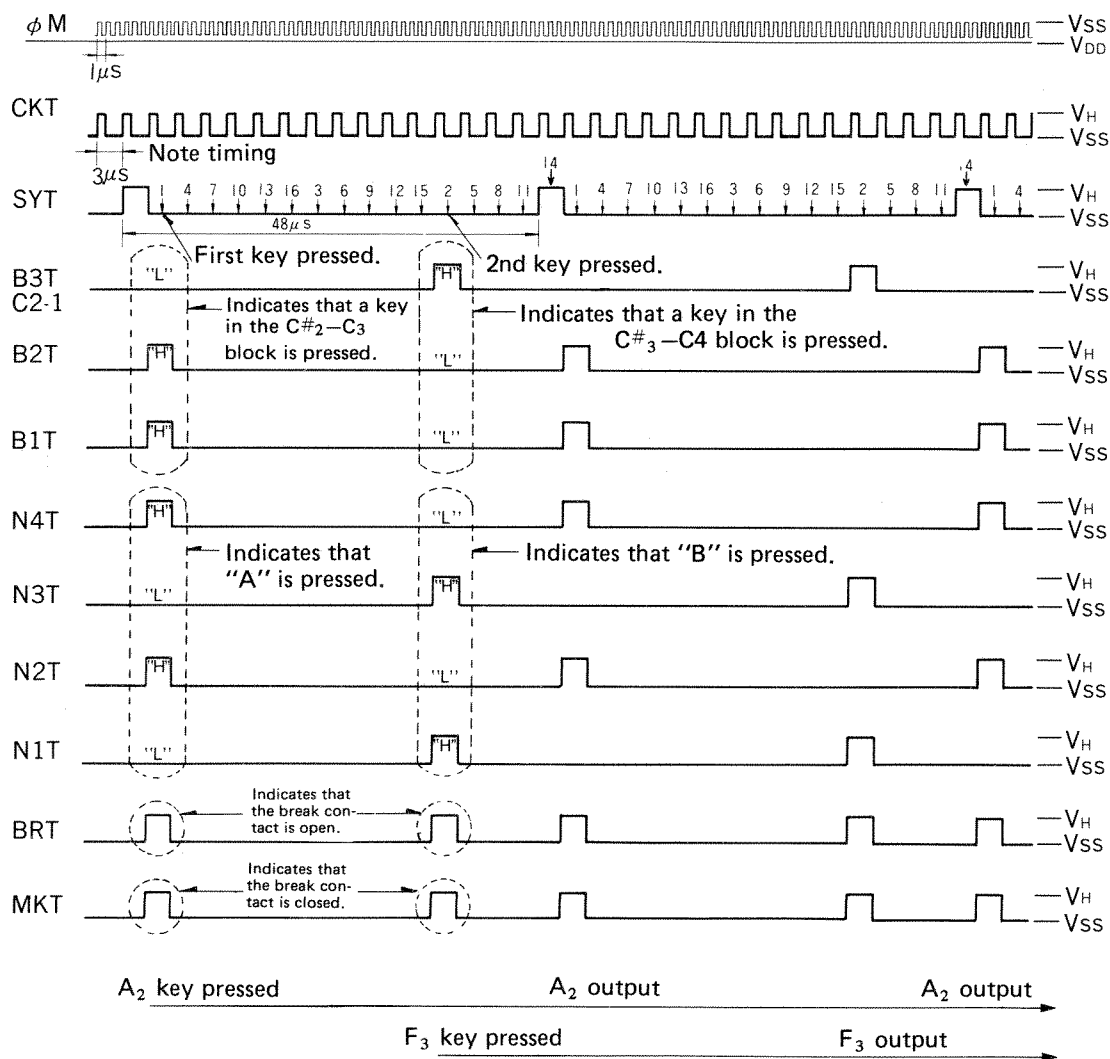

KEYCODE DATA CONVERSION CIRCUIT

Transistors Tr5-Tr10 convert the MOS output level [Vss(0V), Vdd(-15V)] from the key code channel processor IC, IC14(CPA), to TTL logic levels [Vss(0V), Vdd(+5V)]. An inverter is also included.

The data in KCI (BR, BI, NI) are synchronized to appear simultaneously using shift register IC11-4/6-6/6.

IC9-4/6-6/6 forms a latch circuit that stretches the data pulses to 3 microseconds. This operation is carried out on the $KC2$, $KC3$ and $KC4$ signals.

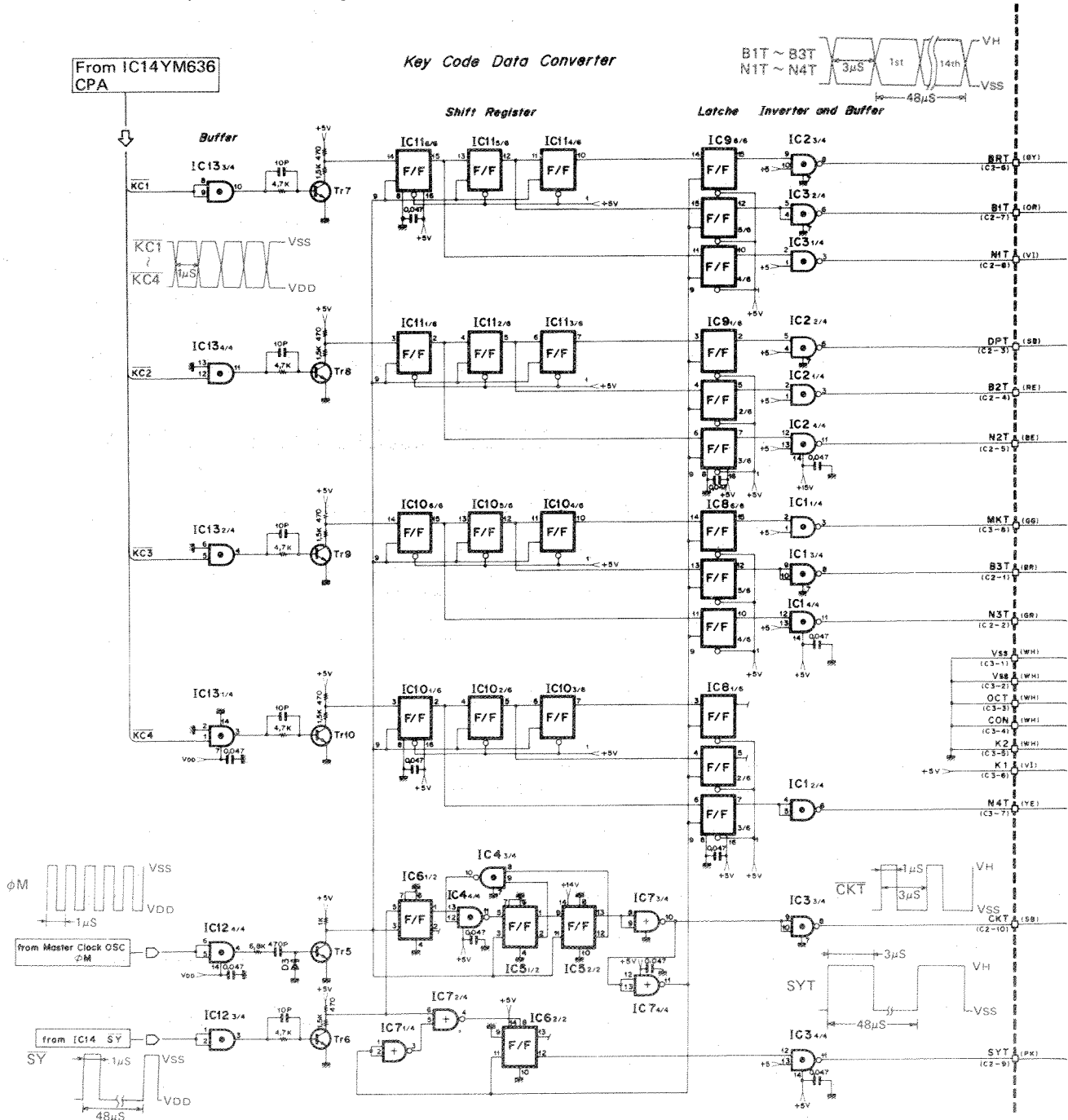

ADJUSTING THE MECHANISM

● Adjusting the velocity keying actuator

*NOTE: Actuator adjustment is preset at the factory, so no adjustment is required unless the key assembly is replaced.

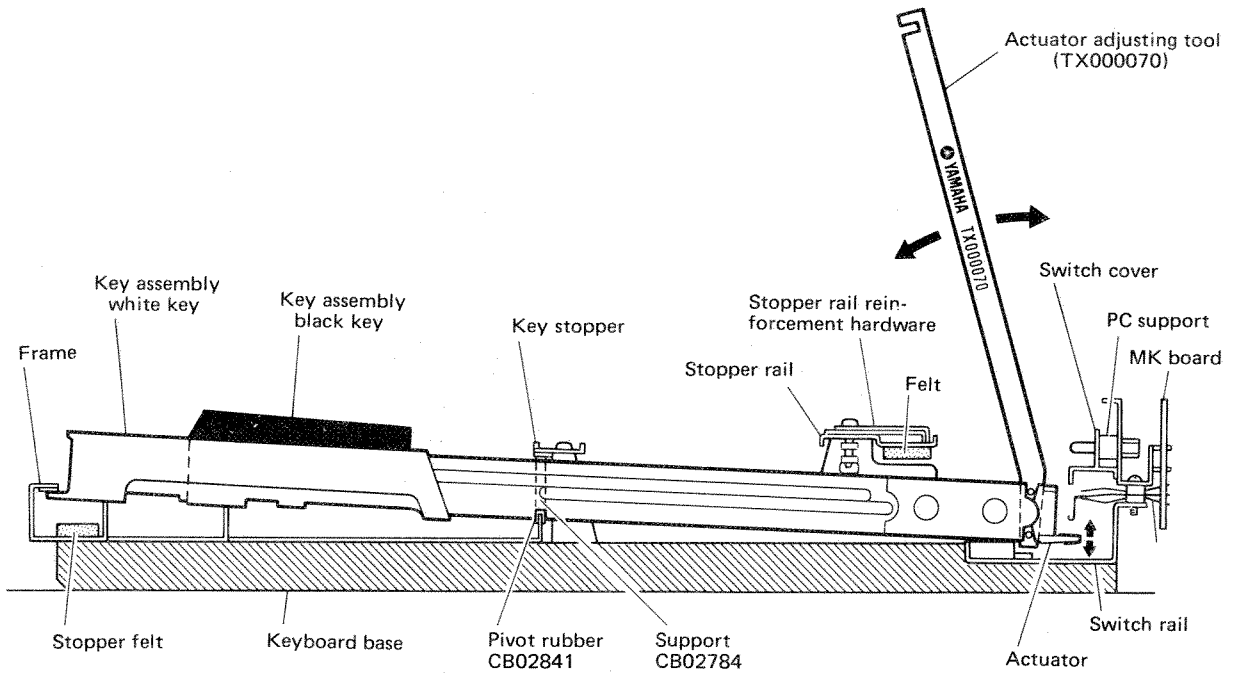

Use the actuator adjusting tool to adjust the level of each key to be the same as the adjacent keys.

* If the level of a note is too low, lower the actuator by moving the adjustment tool forward. Lowering the actuator results in higher velocity thereby increasing level.

* If the level of a note is high, raise the actuator by moving the adjustment tool back. Raising the actuator results in lower velocity thereby decreasing level.

MEMO

.....

.....

.....

.....

.....

.....

.....

.....

.....

.....

BASIC ADJUSTMENT PROCEDURE(ELECTRICAL)

1. Basic panel settings

Initial setting: When power is first turned on the following condition is obtained:

● Power indicator	LED	ON
● Presets 1 (PSW21)	LED	ON
● Filter I-1 (PSW11)	LED	Flashing/Standby Mode
● Filter I-3 (PSW17)	LED	Flashing/Standby Mode
● Other LEDs		OFF

When performing adjustments, all controls should be set as shown in the illustration and chart below except as otherwise indicated.

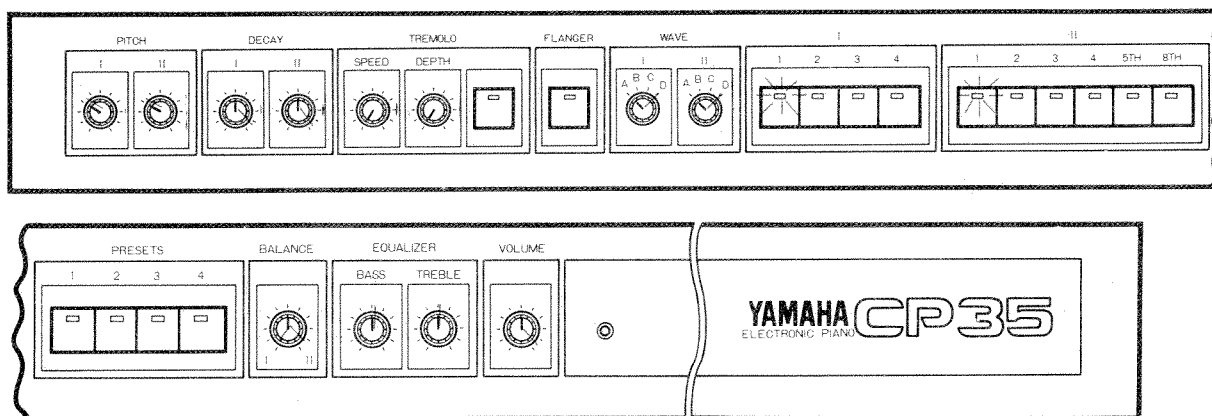

PITCH I (PVR1)	10 o'clock position	II-1 (PSW15)	ON
PITCH II (PVR2)	10 o'clock position	II-2 (PSW16)	OFF
DECAY I (PSW3)	fully clockwise (DECAY MAX)	II-3 (PSW17)	OFF
DECAY II (PSW4)	fully clockwise (DECAY MAX)	II-4 (PSW18)	OFF
TREMOLO SPEED (PVR5)	MINIMUM	5TH (PSW19)	OFF
TREMOLO DEPTH (PVR6)	MINIMUM	8TH (PSW20)	OFF
TREMOLO ON-OFF (PSW7)	OFF	PRESETS 1 (PSW21)	OFF
FLANGER (PSW8)	OFF	PRESETS 2 (PSW22)	OFF
WAVE I (PSW9)	fully clockwise (D position)	PRESETS 3 (PSW23)	OFF
WAVE II (PSW10)	fully clockwise (D position)	PRESETS 4 (PSW24)	OFF
I-1 (PSW11)	ON	BALANCE (PVR25)	fully counter-clockwise when measuring channel I fully clockwise when measuring channel II
I-2 (PSW12)	OFF	EQUALIZER BASS (PVR26)	Centered
I-3 (PSW13)	OFF	EQUALIZER TREBLE (PVR27)	Centered
I-4 (PSW14)	OFF	VOLUME (PVR28)	MAXIMUM

2. Tuning

Test Equipment	Tuning scope
Control Settings	PITCH I, PITCH II at 10 o'clock.
Adjustment Specification	$A_3 = 440\text{Hz}$
Procedure	Adjust master oscillator coils "L1" and "L2" on the KC board for 440Hz while depressing the A_3 key

3. Procedures for adjusting individual boards

- Test equipment
tuning scope
digital voltmeter
oscilloscope

- Circuit Boards and Their Functions

Circuit Board	Function
DM	clock generators I & II key assigner tone generators I & II keycode convertor initial clear circuit
FL	filters channel I – 1, 2, 3, 4, channel II – 1, 2, 3, 4 preset – 1, 2, 3, 4
PN2 PN3	filter selection switch filter I – 1 ~ 4 filter II – 1 ~ 4 preset – 1 ~ 4 5th, 8th select switch LED flasher
EFT	flanger effect circuit BBD device driver circuit componder, expander circuits tremolo effect circuits (2) photo coupler driver circuits (2)

Circuit Board	Function
EFT	output circuits unbalanced output circuit balanced output circuit headphone output circuit muting circuit
PN1	Pitch control I & II circuits Decay switch I & II circuits tremolo switch speed depth flanger switch Wave switch I & II circuits
PN4	Balance control circuit equalizer (bass & treble) control circuits master volume circuit
DC	+5, -15V regulators (for digital circuits) +15, -15V regulators (for analog circuits)

IC DATA CHART

Part Name	YM722000	Function Name	CPB (Combo Piano-B) Tone Generator
-----------	----------	---------------	------------------------------------

Terminal			Terminal		
Pin No.	Name	I/O	Pin No.	Name	I/O
1	VSS	I	48	ϕ M	I
2	\overline{IC}	I	47	VDD	I
3	$\overline{KC1}$	I	46	ϕ CP	I
4	$\overline{KC2}$	I	45	WS0	I
5	$\overline{KC3}$	I	44	WS1	I
6	$\overline{KC4}$	I	43	HS2	O
7	5th UP	I	42	HS3	O
8	8th UP	I	41	HS4	O
9	SY	I	40	HS5	O
10	\overline{CS}	I	39	HS6	O
11	$\overline{E0}$	I	38	AG2	I
12	$\overline{E1}$	I	37	HA2	O
13	$\overline{E2}$	I	36	HA3	O
14	AG1	I	35	HA4	O
15	C1A	I	34	HA5	O
16	C1B	I	33	HA6	O
17	C2B	I	32	-5V	I
18	C2A	I	31	AMIN	I
19	C3A	I	30	C8A	I
20	C3B	I	29	C8B	I
21	C4B	I	28	C7B	I
22	C4A	I	27	C7A	I
23	C5A	I	26	C6A	I
24	C5B	I	25	C6B	I

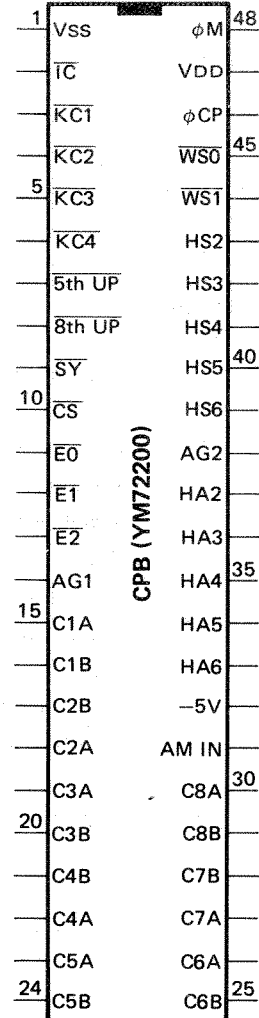

MEMO

.....

.....

.....

.....

.....

.....

.....

.....

.....

.....

YAMAHA

ELECTRONIC PIANO

CP35

PARTS LIST

CONTENTS

A. Electronic Components	1
B. Cabinet Assembly	4
C. Top Board Assembly	7
D. Keyboard Assembly	9
E. Sustainer Pedal	11

A. Electronic Components

Ref. No.	Part No.	Description	部 品 名	Remarks	Common Model	Markets
※	NA:10:69:20	Circuit Board, PN	# 2883	P N シ ー ト		
※	NA:10:69:30	- do. - , EFT	# 2884	E F T //		
※	NA:10:69:40	- do. - , DM	# 2885	D M //		
※	NA:10:69:50	- do. - , FL	# 2886	F L //		
※	NA:10:69:60	- do. - , JK	# 2887	J K //		
※	NA:10:69:70	- do. - , DC	# 2888	D C //		J
※	NA:10:69:80	- do. - , - do. -	- do. -	//		U,C
※	NA:10:69:90	- do. - , - do. -	- do. -	//		G
※	NA:10:70:30	- do. - , AC	# 2891	A C シ ー ト		J
※	NA:10:70:40	- do. - , - do. -	- do. -	//		U
※	NA:10:70:50	- do. - , - do. -	- do. -	//		G
※	NA:10:74:10	- do. - , - do. -	- do. -	//		C
※	NB:10:35:10	Power Transformer Assembly	# 8258	電 源 ト ラ ン ス A s s ' y		G
※	NB:10:41:50	- do. -	# 0393	//		J,U
※	NB:10:41:60	- do. -	# 0393	//		C
※	NB:81:76:90	Switch Assembly	33Key	ス イ ッ チ A s s ' y		
※	NB:81:77:00	- do. -	40Key	//		
※	NB:80:76:00	Switch Unit	6Key	ス イ ッ チ ユ ニ ッ ト		
※	NB:80:76:10	- do. -	3Key	//		
※	NB:81:75:70	- do. -	4Key	//		
	i G:00:11:70	IC	TC4001BP	I C	2-input NOR	
	i G:00:11:80	- do. -	TC4013BP	//	D Flip-Flop	
	i G:00:12:40	- do. -	TC4011BP	//	2-input NAND	
	i G:00:12:60	- do. -	TC4049BP	//	Buffer/Converter	
	i G:00:13:90	- do. -	NJM4558DV	//	OP. Amp	
	i G:00:17:60	- do. -	TC4081BP	//	2-input AND	
	i G:02:74:00	- do. -	TA7220P	//	Amp	
	i G:02:87:00	- do. -	μPC14315H	//	+15V Regulator	
	i G:03:13:00	- do. -	NE570N	//	Noise Reduction	
	i G:03:29:00	- do. -	# 3290	//	BBD Driver	
	i G:03:33:00	- do. -	μPC14305H	//	+5V Regulator	
	i G:04:61:00	- do. -	MN3009	//	256 Stage BBD	
	i G:05:08:00	- do. -	TC40174BP	//	D Flip-Flop	
※	i G:05:34:00	- do. -	HD74LS37P	//	2-input NAND	
※	i T:63:60:00	- do. -	YM63600	//	CP-A (Key coder Channel Processor)	
※	i T:72:20:00	- do. -	YM72200	//	CP-B (Tone Generator)	
	i A:05:09:10	Transistor	2SA509 (Y)	ト ラ ン ジ ス ト		
	i A:10:15:70	- do. -	2SA1015 (O,Y)	//		
	i C:07:52:20	- do. -	2SC752 (Y)	//		
	i C:18:15:70	- do. -	2SC1815 (O,Y)	//		
	i E:10:12:00	FET	2SK105 (F)	F E T		
	i F:00:00:40	Diode	1S1555	ダ イ オ ー ド		
	i H:00:04:70	- do. -	1D4B1	//		
※	i K:00:03:40	Photo Coupler	P1501	フ ォ ト カ プ ラ ー		
	i L:00:05:80	Mica Base		マ イ カ ベ ー ス		
	CB:07:28:80	Insulation Bushing		絶 縁 ブ ッ シ ュ		

※ New Parts (新規部品) (J : Japan, U : US.American, C : Canadian, G : General)

Ref. No.	Part No.	Description	部 品 名	Remarks	Common Model	Markets
	HS 31 04 40	Variable Resistor	B50K Ω	ロータリーボリューム	TREBLE, BASS	
	HS 31 05 50	-- do. --	A10K Ω	"	MASTER VOL.	
	HS 31 05 70	-- do. --	B10K Ω	"	PITCH, TREMOLO DEPTH	
	HS 31 13 30	-- do. --	C100K Ω	"	TREMOLO SPEED	
*	HS 31 14 20	-- do. --	BH10K Ω x2	"	BALANCE	
	HT 37 00 20	Semi Variable Resistor	B10K Ω	半 固 定 抵 抗		
	HT 37 01 00	-- do. --	B50K Ω	"		
	HV 35 43 30	Flame-Proof Carbon Resistor	33 Ω	不 燃 化 カ ー ボ ン 抵 抗		
	HV 35 52 20	-- do. --	220 Ω	"		
	HW99 45 60	Fuse Resistor	56 Ω	ヒ ュ ー ズ 抵 抗	FN19560	
	FD 65 22 70	Polystyrene Capacitor	270PF	スチロールコンデンサ		
	FD 65 26 80	-- do. --	680PF	"		
	FL 63 64 70	B.P. Electrolytic Cap.	4.7 μ F/16V	B. P. ケ ミ コ ン		
	FL 63 71 00	-- do. --	10 μ F/16V	"		
	FL 63 72 20	-- do. --	22 μ F/16V	"		
	FL 66 64 70	-- do. --	4.7 μ F/50V	"		
	FM 80 92 20	Electrolytic Capacitor	2200 μ F/35V	ケ ミ コ ン		
	UJ 15 91 00	-- do. --	1000 μ F/35V	"		
	UJ 13 91 00	-- do. --	1000 μ F/16V	"		
*	UL 14 66 80	-- do. --	6.8 μ F/25V	"	Lo Noise	
	FZ 00 22 50	Spark Suppressor Cap.	0.022 μ F	スパーキアラコンデンサ		
	FZ 00 28 50	-- do. --	0.0022 μ F	"		U
	KA 10 10 60	Power Switch		パ ワ ー ス イ ッ チ		
	KA 40 08 10	Slide Switch	4-2	ス ラ イ ド ス イ ッ チ	LINE SW	
	KA 40 08 30	Voltage Selector		電 圧 切 替 器		
	KA 50 17 20	Rotary Switch	1-8	ロ ー タ リ ー ス イ ッ チ	DECAY I, II	
	KA 50 17 00	-- do. --	3-4	"	WAVE I, II	
	KA 90 17 01	Push Switch W/LED	Gray	プ ッ シ ュ ス イ ッ チ	TREMOLO, FLANGER 5TH, 8TH UP	
	KA 90 17 11	-- do. --	White	"	FILTER, PRESET	
	KB 00 03 10	Fuse	0.5A 250V	ヒ ュ ー ズ		J
	KB 00 03 30	-- do. --	1A 250V	"		J
	KB 00 03 40	-- do. --	1.5A 250V	"		J
	KB 00 07 10	-- do. -- (Miniature)	T500mA 250V	ミニチュアヒューズ		G
	KB 00 07 30	-- do. -- -- do. --	T1A 250V	"		G
	KB 00 10 60	-- do. --	1A 250V	ヒ ュ ー ズ		U,C
	KB 00 11 50	-- do. --	0.5A 250V	"		U,C
	KB 00 15 90	-- do. --	1.5A 250V	"		U,C
*	KC 00 13 00	Relay	RZ12	リ レ ー		
	GD 90 02 50	Line Transformer		ラ イ ン ト ラ ン ス		
	GE 30 03 50	Choke Coil	68 μ H	チ ョ ー ク コ イ ル		
	GE 90 03 40	OSC Coil	200 μ H	OSC コ イ ル		

* New Parts (新規部品)

Ref. No.	Part No.	Description	部 品 名	Remarks	Common Model	Markets
	GE 90 05 00	Coil	CK4	コ イ ル		U
	GE 90 05 30	- do. -	CK6	"		U
	MG 00 10 30	AC Cord		電 源 コ ー ド		J
	MG 00 10 40	- do. -		"		U
	MG 00 10 50	- do. -		"		G
	MG 00 12 80	- do. -		"		C
	LB 20 18 20	AC Inlet	2P	A C イ ン レ ッ ト		J,U,C
	LB 20 18 60	- do. -	- do. -	"		G
	LB 20 15 40	Phone Jack		ジ ャ ッ ク		
	LB 30 01 60	Connon Socket	XLR-3-32	キ ャ ノ ン ソ ケ ッ ト		
	LB 20 05 70	Fuse Holder Pin		ヒ ュ ー ズ ホ ル ダ ー ピ ン		
	LB 20 15 30	- do. -		"		
	LB 50 02 50	Connector Base Pin	5P	2.5ピッチベースピン	Top Entry	
	LB 60 24 60	- do. -	7P	"	- do. -	
	LB 60 24 90	- do. -	8P	"	- do. -	
	LB 60 24 70	- do. -	10P	"	- do. -	
	LB 40 05 90	- do. -	4P	"	Side Entry	
	LB 50 02 70	- do. -	5P	"	- do. -	
	LB 60 28 20	- do. -	6P	"	- do. -	
	LB 60 30 20	- do. -	8P	"	- do. -	
	LB 50 03 70	- do. -	5P	"	Bottom Entry	
	LB 60 30 00	- do. -	7P	"	- do. -	
	LB 60 30 70	- do. -	10P	"	- do. -	
	LB 40 05 60	Connector Housing	4P	2.5ピッチハウジング		
	LB 50 02 40	- do. -	5P	"		
	LB 60 28 10	- do. -	6P	"		
	LB 60 24 40	- do. -	7P	"		
	LB 60 24 80	- do. -	8P	"		
	LB 60 24 50	- do. -	10P	"		
	LB 60 15 40	Connector Plug	9P	9 P プ ラ グ		
	LB 60 15 50	Connector Cap	9P	9 P キ ャ ッ プ		
	LB 60 40 40	Connector Housing	8P	ハ ウ ジ ン グ		
	LB 60 39 90	Connector	8P	コ ネ ク タ ー		
	LB 60 39 40	Connector Socket	24P	コ ネ ク タ ー ソ ケ ッ ト		
	BB 00 44 30	Pin Contact		ピ ン コ ン タ ク ト		
	BB 00 49 90	- do. -		"		
	LB 60 16 70	- do. -		"		
	LB 60 16 60	Socket Contact		ソ ケ ッ ト コ ン タ ク ト		

* New Parts (新規部品)

B. Cabinet Assembly

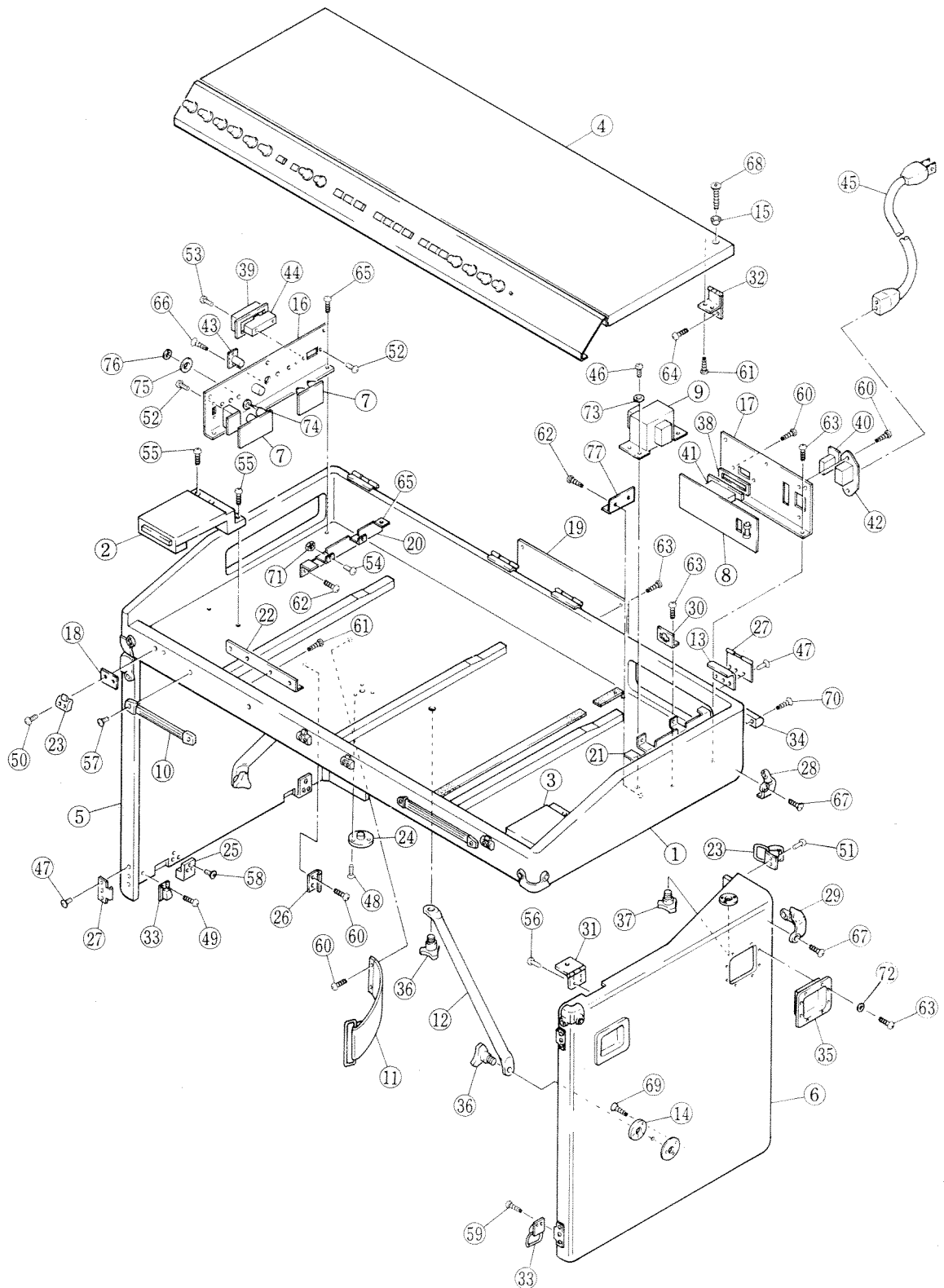

Ref. No.	Part No.	Description	部 品 名	Remarks	Common Model	Markets
* 1	DA:02:45:50	Bottom Case Assembly	底 枱 集 成			
* 2	DA:02:45:70	End-Block Assembly (L)	拍 子 木 集 成 (左)			
* 3	DA:02:45:80	- do. - (R)	" (右)			
* 4	DA:02:45:90	Top-Board Assembly	屋 根 集 成			

* New Parts (新規部品)

Ref. No.	Part No.	Description	部 品 名	Remarks	Common Model	Markets
* 5	DA:02:46:00	Cover Assembly (L)	蓋 脚 集 成 (左)			
* 6	DA:02:46:10	- do. - (R)	" (右)			
* 7	NA:10:69:60	Circuit Board, JK	J K シ ー ト	# 2887		
* 8	NA:10:70:30	- do. - , AC	A C "	# 2891		J
* 9	NA:10:70:40	- do. - , - do. -	"	- do. -		U
* 10	NA:10:70:50	- do. - , - do. -	"	- do. -		G
* 11	NA:10:74:10	- do. - , - do. -	"	- do. -		C
* 12	NB:10:35:10	Power Transformer Assembly	電 源 ト ラ ン ス A s s ' y			G
* 13	NB:10:41:50	- do. -	"			J,U
* 14	NB:10:41:60	- do. -	"			C
15	NB:80:59:50	Handle Assembly	取 手 A s s ' y			
16	NB:80:59:60	Pedal Stopper Band	ペダル止めバンドAss'y			
17	NB:81:69:90	Stay Assembly	脚 柱 A s s ' y			
18	AA:01:46:90	Corner Angle	コ ー ナ ー ア ン グ ル			
19	AA:01:58:70	Stay Washer	脚 受 座 金			
20	AA:02:90:40	Washer	皿 ワ ッ シ ャ ー			
* 21	AA:05:25:40	I/O Panel	I / O パ ネ ル			
* 22	AA:05:25:60	AC Panel	電 源 パ ネ ル			J,U,C
* 23	AA:05:25:70	- do. -	"			G
* 24	AA:05:32:40	Lock Plate	バ ッ チ ン 錠 プ レ ー ト			
* 25	AA:05:26:20	Name Plate	ネ ー ム プ レ ー ト			
* 26	AA:05:26:30	Top Board Holder (L)	屋 根 受 金 具 (左)			
* 27	AA:05:26:40	- do. - (R)	" (右)			
* 28	AA:05:32:00	Handle Plate	取 手 取 付 金 具			
29	AA:80:24:50	Lock	バ ッ チ ン 錠			
30	AA:80:42:70	Nut, Leg	脚 用 ナ ッ ト			
31	AA:80:42:90	Slip Fitting	滑 り 座			
32	AA:80:43:20	Pedal Stopper	引 掛 金 具			
33	AA:80:64:20	Latch Hinge	引 掛 蝶 番			
34	AA:80:90:50	Corner Metal	コ ー ナ ー 金 具			
35	AA:81:47:70	- do. -	"			
36	AA:81:63:00	Connector Holder	コ ネ ク タ ホ ル ダ ー			
37	AA:81:66:30	Leg Hinge	脚 蝶 番			
38	AA:81:73:80	Top Board Hinge	蝶 番			
39	AA:99:00:00	Lock	バ ッ チ ン 錠			
* 40	CB:01:03:10	Case Leg	脚			
* 41	CB:04:02:10	Handle	蓋 脚 取 手			
42	CB:80:83:30	Knob Bolt	ノ ブ ネ ジ			
43	CB:80:83:40	- do. -	"	M8x30		
44	CB:81:78:90	Spacer	ス ペ ー サ ー			
45	CB:81:79:10	Cover	カ バ ー			
46	KA:10:10:60	Power Switch	パ ワ ー ス イ ッ チ			
47	KA:40:08:30	Voltage Selector	電 圧 切 替 器			
48	LB:20:18:20	AC Inlet, 2P	2 P イ ン レ ッ ト			J,U,C
49	LB:20:18:60	- do. - , - do. -	"			G
50	LB:30:01:60	Cannon Socket	キャノンソケット	XLR-3-32		
51	LB:60:39:40	Connector Socket	コネクターソケット	24P		
52	MG:00:10:30	AC Cord	電 源 コ ー ド			J
53	MG:00:10:40	- do. -	"			U
54	MG:00:10:50	- do. -	"			G
55	MG:00:12:80	- do. -	"			C
56	EA:34:01:50	Pan Head Screw	ナ ベ 小 ネ ジ	M4x15 BL		
57	EB:23:01:40	Flat Head Screw	皿 小 ネ ジ	M3x14 Cr		

* New Parts (新規部品)

C. Top Board Assembly

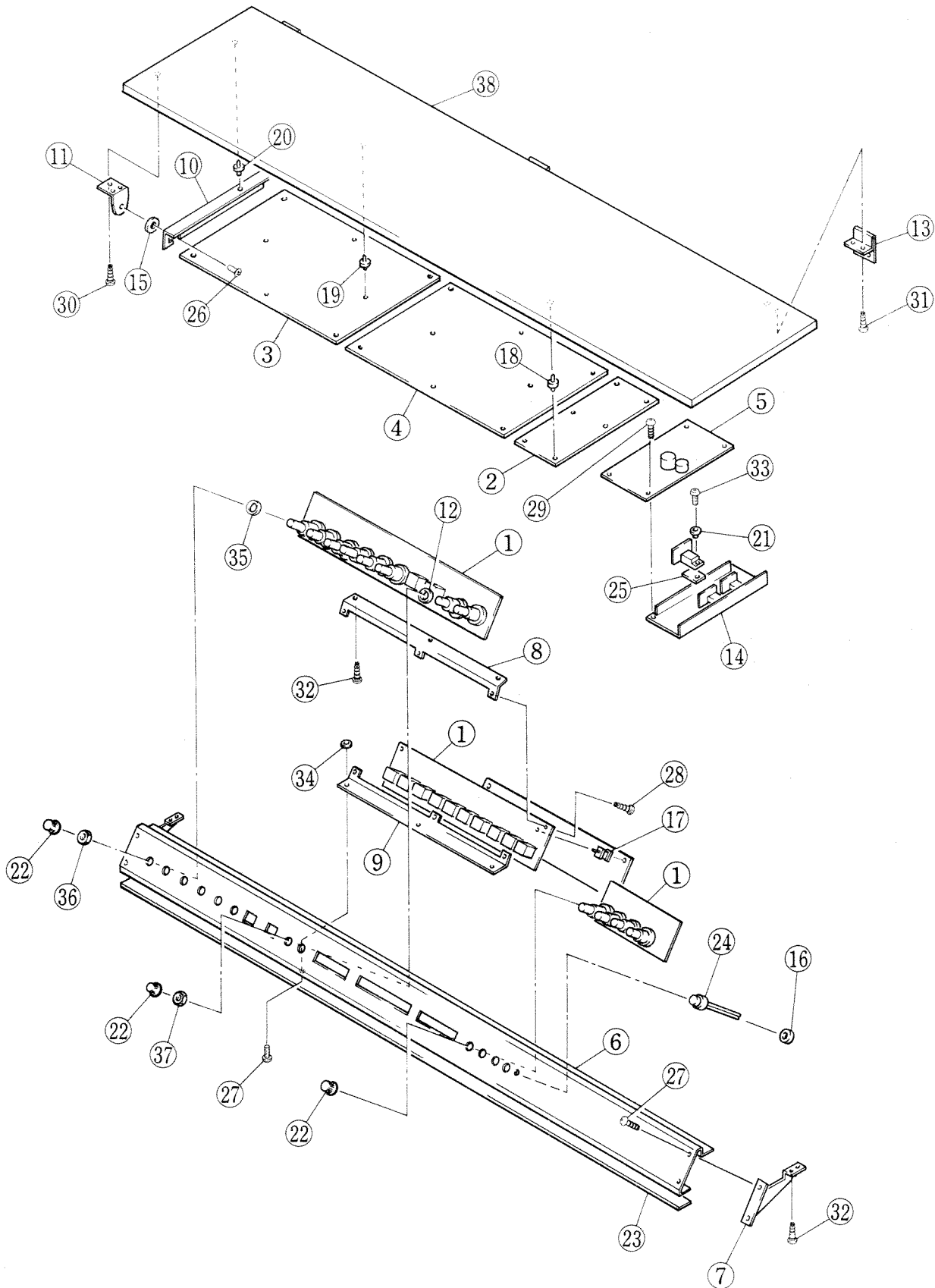

Ref. No.	Part No.	Description	部 品 名		Remarks	Common Model	Markets
※ 1	NA.10.69.20	Circuit Board, PN	# 2883		PN シ ー ト		
※ 2	NA.10.69.30	- do. - , EFT	# 2884		EFT "		
※ 3	NA.10.69.40	- do. - , DM	# 2885		DM "		
※ 4	NA.10.69.50	- do. - , FL	# 2886		FL "		
※ 5	NA.10.69.70	- do. - , DC	# 2888		DC "		J
※	NA.10.69.80	- do. - , - do. -	- do. -		"		U,C
※	NA.10.69.90	- do. - , - do. -	- do. -		"		G
※ 6	AA.05.24.60	Panel			パ ネ ル		
※ 7	AA.05.24.80	Panel Stay			パ ネ ル ス テ ー		
※ 8	AA.05.25.00	Panel Angle (U)			PN 固 定 金 具 U		
※ 9	AA.05.25.10	- do. - (L)			" L		
※ 10	AA.05.26.00	Stay			ス テ ー		
※ 11	AA.05.26.10	Stay Holder			ス テ ー 固 定 金 具		
12	AA.80.58.20	Spacer			ス ペ ー サ ー		
13	AA.81.73.80	Hinge			蝶 番		
14	BA.01.50.70	Heat Sink			ヒ ー ト シ ン ク		
15	CB.01.18.30	Bushing			ブ ッ シ ュ		
16	CB.02.99.30	LED Socket			LED ソ ケ ッ ト		
17	CB.03.84.10	C.B. Holder			シ ー ト ホ ル ダ ー		
※ 18	CB.03.97.50	- do. -			"		
19	CB.04.00.80	- do. -			"		
20	CB.08.70.00	- do. -			"		
21	CB.07.28.80	Insulation Bushing			絶 縁 ブ ッ シ ュ		
22	CB.81.01.20	Knob			ツ マ ミ		
※ 23	CC.01.52.90	Panel Felt			パ ネ ル 貼 フェ ル ト		
24	i F.00.02.90	LED			L E D		
25	i L.00.05.80	Mica Base			マ イ カ ベ ー ス		
26	EB.34.01.20	Flat Head Screw	M4x12	BL	皿 小 ネ ジ		
27	EC.33.00.80	Truss Screw	M3x8	BL	ト ラ ス 小 ネ ジ		
28	ED.33.00.60	Bind Screw	M3x6	BL	バ イ ン ド 小 ネ ジ		
29	E i.33.00.80	Bind Tapping Screw	3x8	BL	バ イ ン ド タ ッ ピ ン グ ネ ジ		
30	E i.33.01.00	- do. -	3x10	BL	"		
31	E i.33.01.20	- do. -	3x12	BL	"		
32	E i.33.51.20	- do. -	3.5x12	BL	"		
33	EL.32.60.80	Sems Screw	M2.6x8	BL	セ ム ス 小 ネ ジ		
34	EV.41.00.30	Toothed Lock Washer	A3S	Ye	歯 付 座 金		
35	EV.41.00.70	- do. -	A7S	Ye	"		
36	EZ.30.70.10	Hexagonal Nut	M7	Ye	特 殊 六 角 ナ ッ ト		
37	EZ.30.90.10	- do. -	M9	Ye	"		
38	DA.02.45.90	Top Board Assembly			屋 根 集 成		

※ New Parts (新規部品)

D. Keyboard Assembly

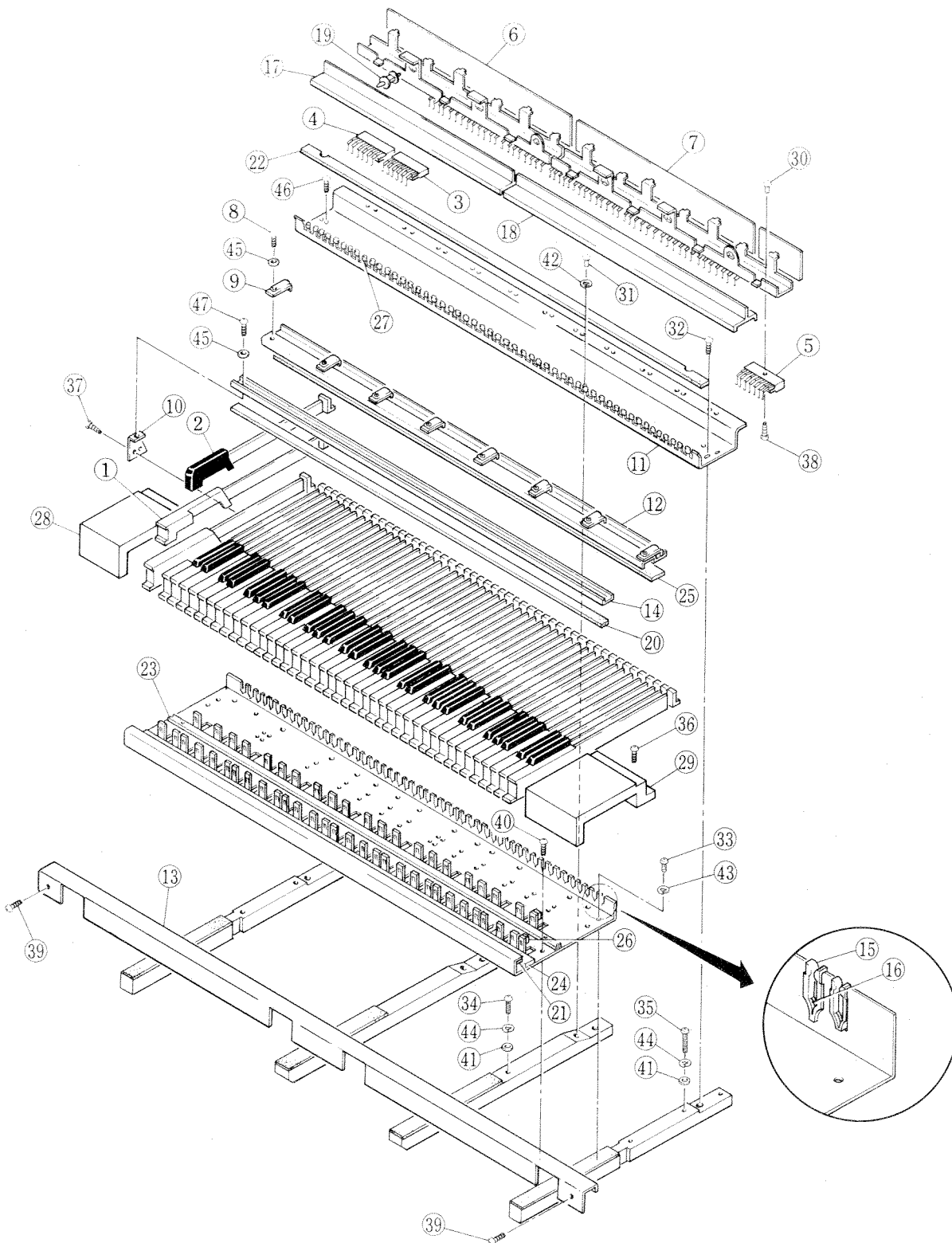

Ref. No.	Part No.	Description	部品名	Remarks	Common Model	Markets
1	NB:04:51:00	White Key Assembly	白 鍵 Ass'y			
	NB:04:34:30	- do. -	"			
	NB:04:34:40	- do. -	"			
	NB:04:34:50	- do. -	"			

* New Parts (新規部品)

Ref. No.	Part No.	Description	部 品 名		Remarks	Common Model	Markets
	NB:04:34:60	White Key Assembly	G		白 鍵 Ass'y		
	NB:04:34:70	- do. -	A		"		
2	NB:04:35:10	Black Key Assembly			黒 鍵 Ass'y		
3	NB:80:76:00	Switch Unit	6Key		スイッチユニット		
4	NB:80:76:10	- do. -	3Key		"		
※ 5	NB:81:75:70	- do. -	4Key		"		
※ 6	NB:81:76:90	Switch Assembly	33Key		ス イ ッ チ Ass'y		
※ 7	NB:81:77:00	- do. -	40Key		"		
8	ES:04:02:00	Tap Tight Screw	4 X 20	Ye	タップタイトネジ		
9	AA:80:46:40	Guard, Stopper Rail			ストップパーレール補強金具		
10	AA:80:46:50	Stay (B)			ス テ - (B)		
※ 11	AA:81:67:80	Switch Rail			スイッチレール		
※ 12	AA:81:68:00	Stopper Rail			ストップパーレール		
※ 13	AA:05:32:10	Front Rail			ロ 金		
※ 14	AA:81:68:40	Key Stopper			キーストッパー		
15	CB:02:78:40	Support			サ ポ - ト		
16	CB:02:84:10	Pivot Rubber			ピボットゴム		
※ 17	CB:03:97:80	Switch Cover			スイッチカバー		
※ 18	CB:03:97:90	- do. -			"		
19	CB:81:78:10	PC Support			PC サ ポ - ト		
※ 20	CB:81:87:30	Key Stopper Rubber			キーストッパーゴム		
※ 21	CC:02:19:50	Stopper Felt			ストップパーフェルト		
※ 22	CC:07:04:40	- do. -			"		
※ 23	CC:07:04:60	- do. -			"		
※ 24	CC:07:04:80	- do. -			"		
※ 25	CC:07:05:00	- do. -			"		
26	CD:01:00:50	Key Guide Cloth			キーガイドクロス		
27	CH:00:02:90	Tube	Between White & White Key		ヒシチューブ		
	CH:00:03:00	- do. -	Between White & Black Key		"		
※ 28	DA:02:45:70	End Block Assembly (L)			拍子木集成 (左)		
※ 29	DA:02:45:80	- do. - (R)			" (右)		
30	EA:03:01:20	Pan Head Screw	M3x12	Ye	ナベ小ネジ		
31	EA:04:01:60	- do. -	M4x16	Ye	"		
32	EA:05:01:60	- do. -	M5x16	Ye	"		
33	EA:05:02:00	- do. -	M5x20	Ye	"		
34	EA:35:03:00	- do. -	M5x30	BL	"		
35	EA:35:03:50	- do. -	M5x35	BL	"		
36	Ei:33:52:00	Bind Tapping Screw	3.5x20	BL	バインドタッピングネジ		
37	EJ:03:00:60	Pan Head Tapping Screw	3x6	Ye	ナベタッピングネジ		
38	EJ:03:01:20	- do. -	3x12	Ye	"		
39	EH:33:51:20	Truss Tapping Screw	3.5x12	BL	トラスタッピングネジ		
40	EQ:03:51:30	Round Head Wood Screw	3.5x13	Ye	丸木ネジ		
41	EV:20:30:50	Flat Washer	5S	BL	平座金		
42	EV:30:00:40	Spring Lock Washer	4S	Ye	バネ座金		
43	EV:30:00:50	- do. -	5S	Ye	"		
44	EV:30:30:50	- do. -	5S	BL	"		
45	EV:42:00:40	Toothed Lock Washer	B4S	Ye	歯付座金		
46	ES:04:01:20	Tap Tight Screw	4x12	Ye	タップタイトネジ		
47	ES:04:01:50	- do. -	4x15	Ye	"		

※ New Parts (新規部品)

E. Sustainer Pedal

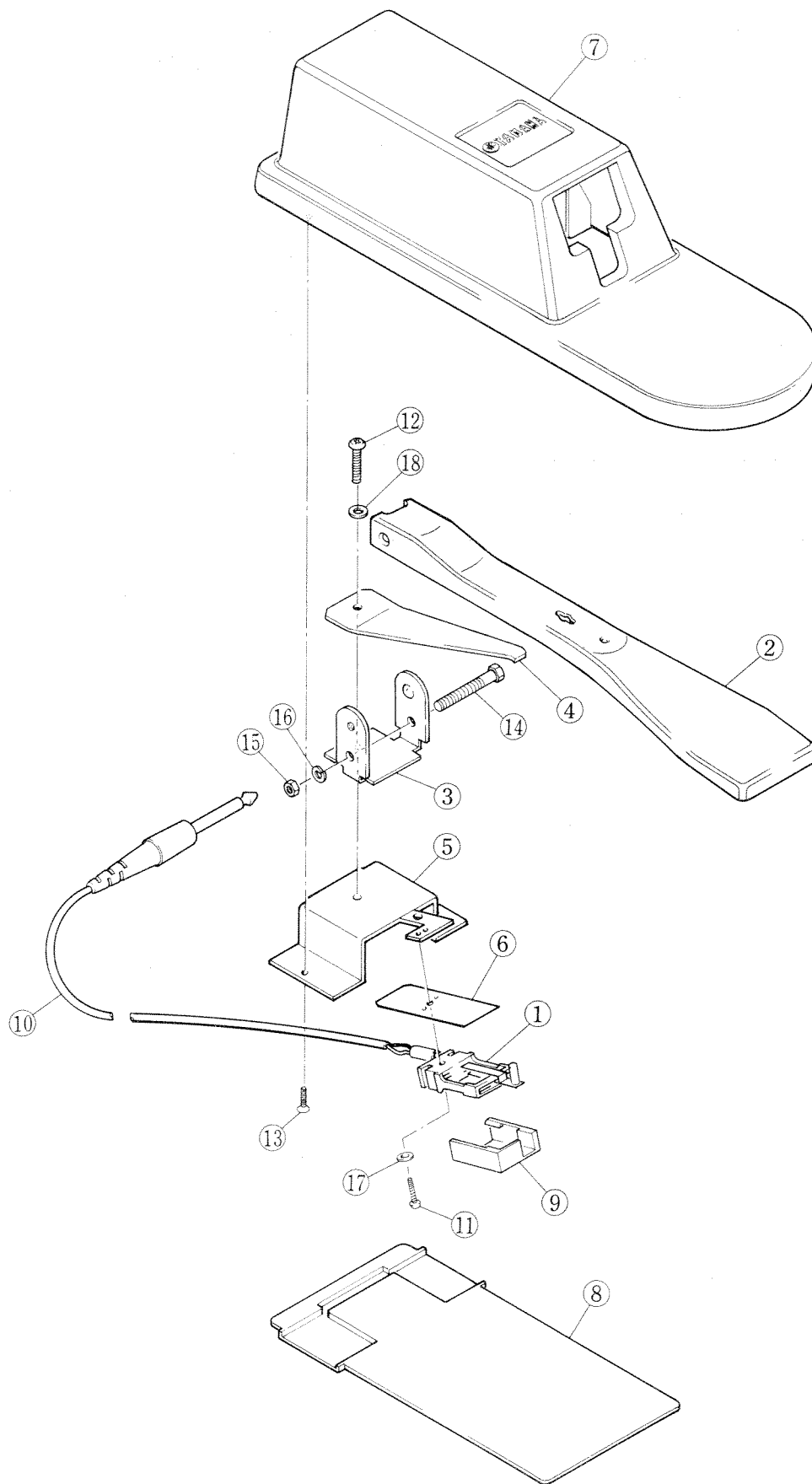

CP35 SERVICE MANUAL

1981年12月 初版

発 行 所 日本楽器製造株式会社
電音サービス課

パーツリスト 豊立設計事務所

本文・総回路図
版 下 ・ 印 刷 中部電子印刷株式会社

**NE570
COMPANDER**

R Gate

Diagram

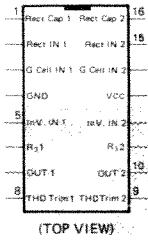
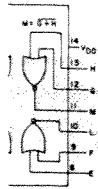

Block & Schematic Diagram

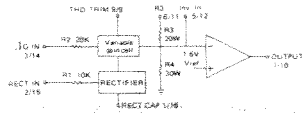

**NJM4558DV
Dual Operational Amplifier**

Logic Diagram

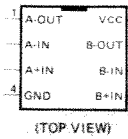
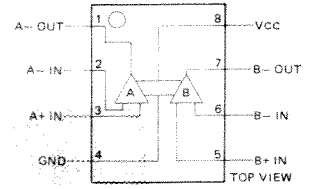

**iG03290
BBD driver**

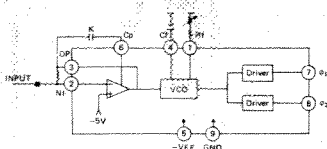
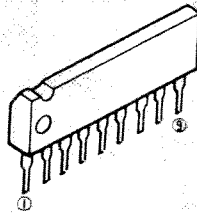

①	②	③	④	⑤	⑥	⑦	⑧	⑨
Rf	-IN	OP	Cf	VEE	Cp	φ1	φ2	GND

**MN3009
256 stage BBD**

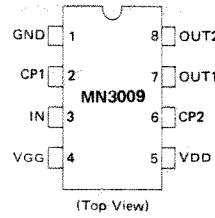

**TA7220P
LOW POWER AMP.
P SIP 10 PIN (with Tab)**

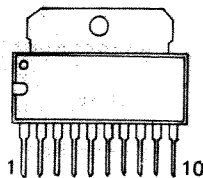

3pin: INPUT
8pin: OUTPUT

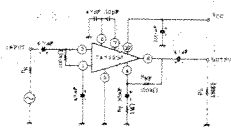

**μPC14305H
μPC14315H
P 3 PIN**

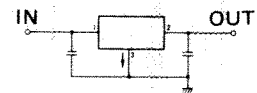

Pin No.	①	③	②
Pin Name	IN	GND	OUT
μPC14305H	10V		5V
μPC14315H	23V		15V

DM Circuit Diagram

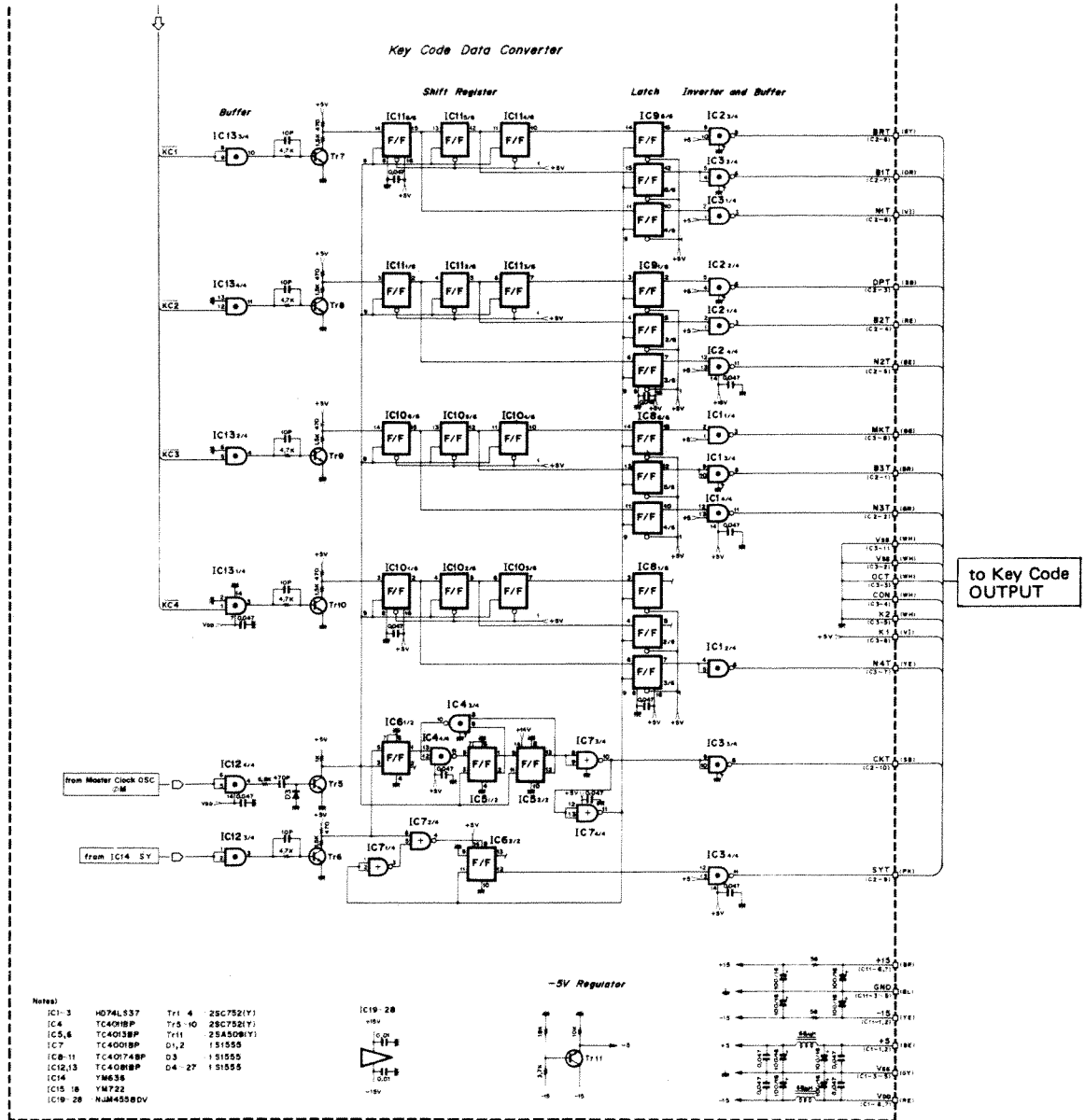

(IC3-2,4,6,8,10)
g/Filter II and Presets

(IC5-2,4,6,8,10)
g/Filter II and Presets

FL Circuit Board & Wining

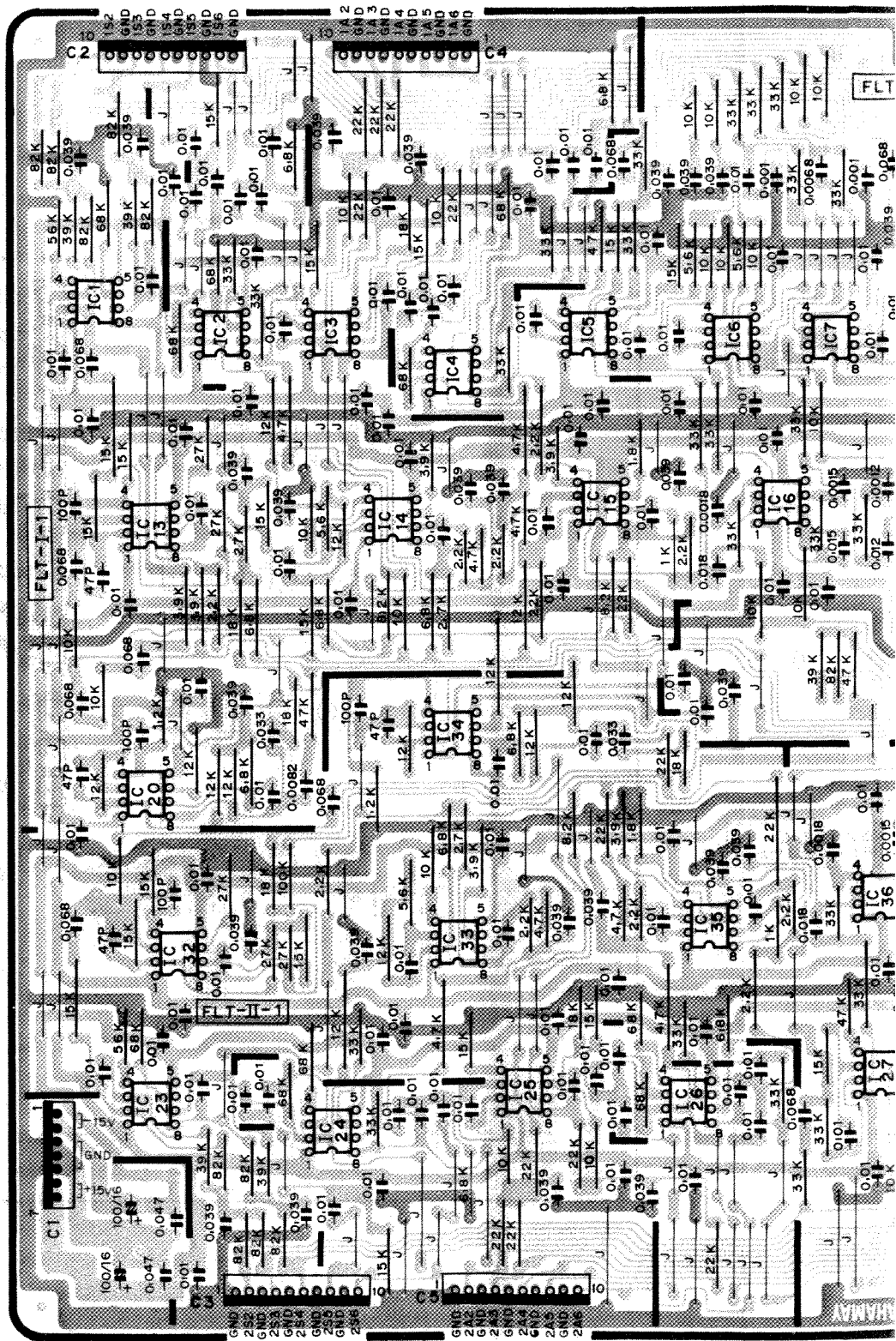

Component Side (部品側)

EFT Circuit Diagram

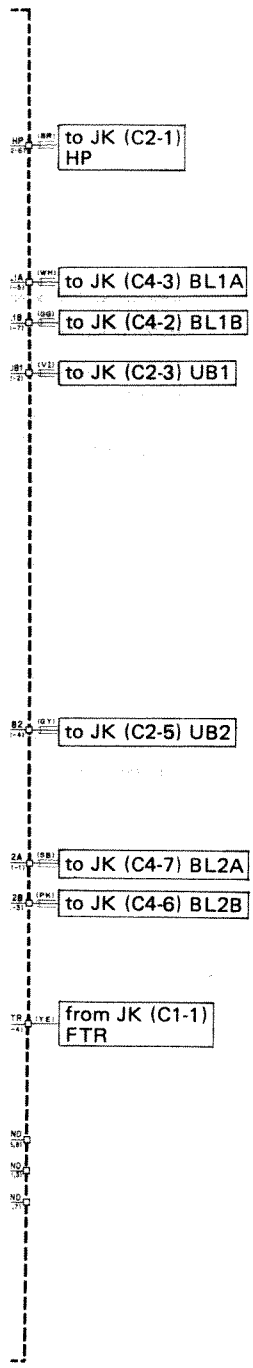

Item	Setting	Test Point	Adjustment	Adj. Point	Rem.
FLANGER OSC		IC5 pin 7	 f = 0.5 ± 0.3Hz		Check
		IC1 pin 7 pin 8	 f = 120kHz ~ 25kHz Make sure that FM mod. is applied in above freq. range.		Check
FLANGER WAVEFORM	FILTER I - 1 only on. Press C ₅ key.	IC3 pin 10	 Adj. for perfect symmetry.	VR7	Adj.
TREMOLO OSC	TREMOLO SPEED -MAX	IC10 pin 7	 f = 15 ± 0.5Hz	VR1	Adj.
	Speed TREMOLO SPEED -MIN	IC10 pin 7	 f = 0.5 ± 0.4Hz		Check
	Depth TREMOLO DEPTH -MAX	IC11 pin 1 IC11 pin 1	 Adjust for sine-wave.	VR2	Adj.
	TREMOLO SW -ON				
MODULATION BALANCE					
OUT 1		IC9 pin 1		VR3	Adj.
OUT 2		IC9 pin 7	 Adjust for 95% mod. Check that IC9 pin 1 is 180 degrees out of phase.	VR4	Adj.
UNBALANCED output circuit	FILTER I - 1 -ON	EQ (C3-6)	Adjust so 0.8 times the EQ terminal input signal appears at UB1, UB2.		
OUT 1		UB1 (C2-2)	power ON	VR5	Adj.
OUT 2	C ₅ Key -ON	UB2 (C2-4)	power OFF	VR6	Adj.
MUTING	Power	Tr6 Emitter	 2 sec ± 20% 3msec		Check

PN1, 4 Circuit Diagram

DECAY SW. Data

POSITION	1	2	3	4	5	6	7	8
1E2 (C2-4)	H	H	H	H	L	L	L	L
2E2 (C2-7)	H	H	L	L	H	H	L	L
1E1 (C2-3)	H	H	L	L	H	H	L	L
2E1 (C2-6)	H	L	H	L	H	L	H	L

"H" = 0V
 "L" = -15V

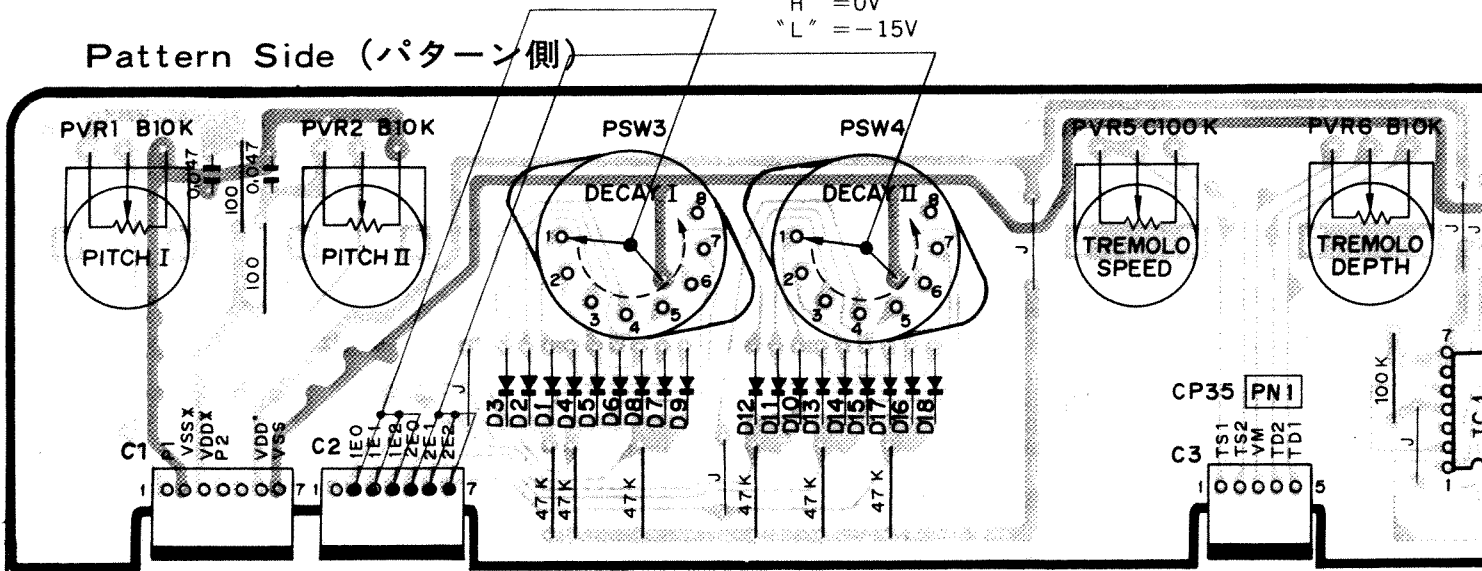

● Connector

C1

Pin No.	Pin Name	Wire Color	Destination
1	P1	SB	DM-P1 (C4-2)
2	Vss*	WH	DM-Vss* (C4-3)
3	Vdd*	OR	DM-Vdd* (C4-5)
4	P2	PK	DM-P2 (C4-4)
5	-	-	-
6	Vdd*	PK	PN3-Vdd* (C7-1)
7	Vss	GY	PN3-Vss (C7-3)

C2

Pin No.	Pin Name	Wire Color	Destination
1	-	-	-
2	1E0	BR	DM-1E0 (C10-2)
3	1E1	RE	DM-1E1 (C10-3)
4	1E2	OR	DM-1E2 (C10-4)
5	2E0	YE	DM-2E0 (C9-5)
6	2E1	GR	DM-2E1 (C9-6)
7	2E2	BE	DM-2E2 (C9-7)

C3

Pin No.	Pin Name	Wire Color	Destination
1	TS1	BE	EFT-TS1 (C5-3)
2	TS2	GR	EFT-TS2 (C5-2)
3	VM	WH	EFT-VM (C5-6)
4	TD2	GY	EFT-TD2 (C5-5)
5	TD1	VI	EFT-TD1 (C5-7)

C4

Pin No.	Pin Name	Wire Color	Destination
1	TR	OR	EFT-TR (C5-1)
2	FG	RE	EFT-FG (C3-3)
3	MS	BR	PN3-MS (C9-1)
4	PR4	PK	PN3-PR4 (C9-3)
5	PR3	SB	PN3-PR3 (C9-5)
6	PR2	GG	PN3-PR2 (C9-7)
7	PR1	WH	PN3-PR1 (C9-9)

C5

Pin No.	Pin Name	Wire Color	Destination
1	-	-	-
2	2WS0	WH	DM-2WS0 (C9-1)
3	1WS1	GY	DM-1WS1 (C10-4)
4	1WS0	VI	DM-1WS0 (C10-5)
5	2WS1	GG	DM-2WS1 (C9-2)

AC Circuit Board & Wiring, Circuit Diagram

LC 28910
150V

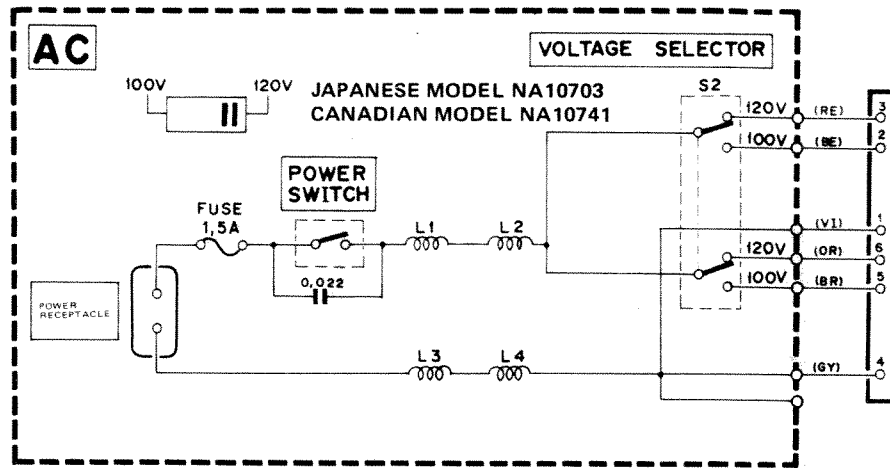

LC 28910
150V

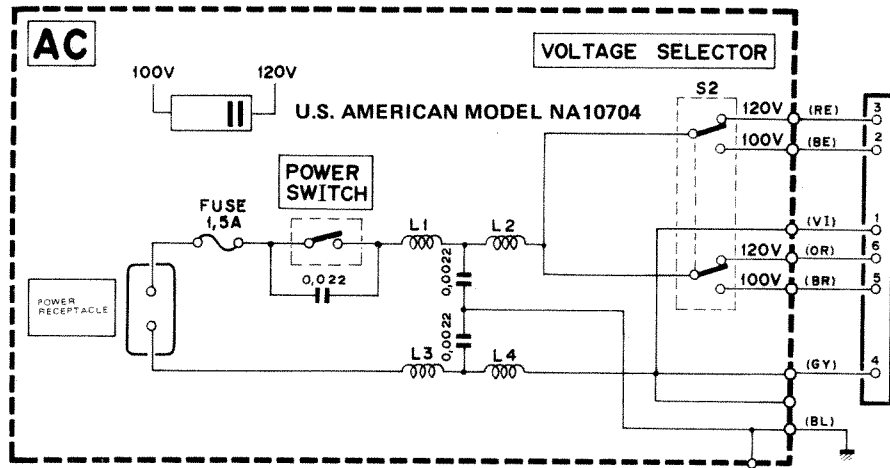

LC 28910
150V

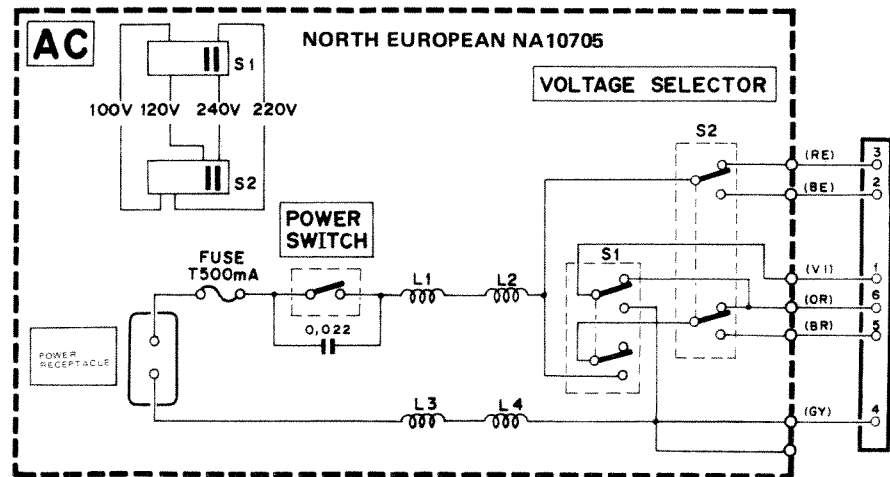

DC Circuit Board & Wiring, Circuit Diagram

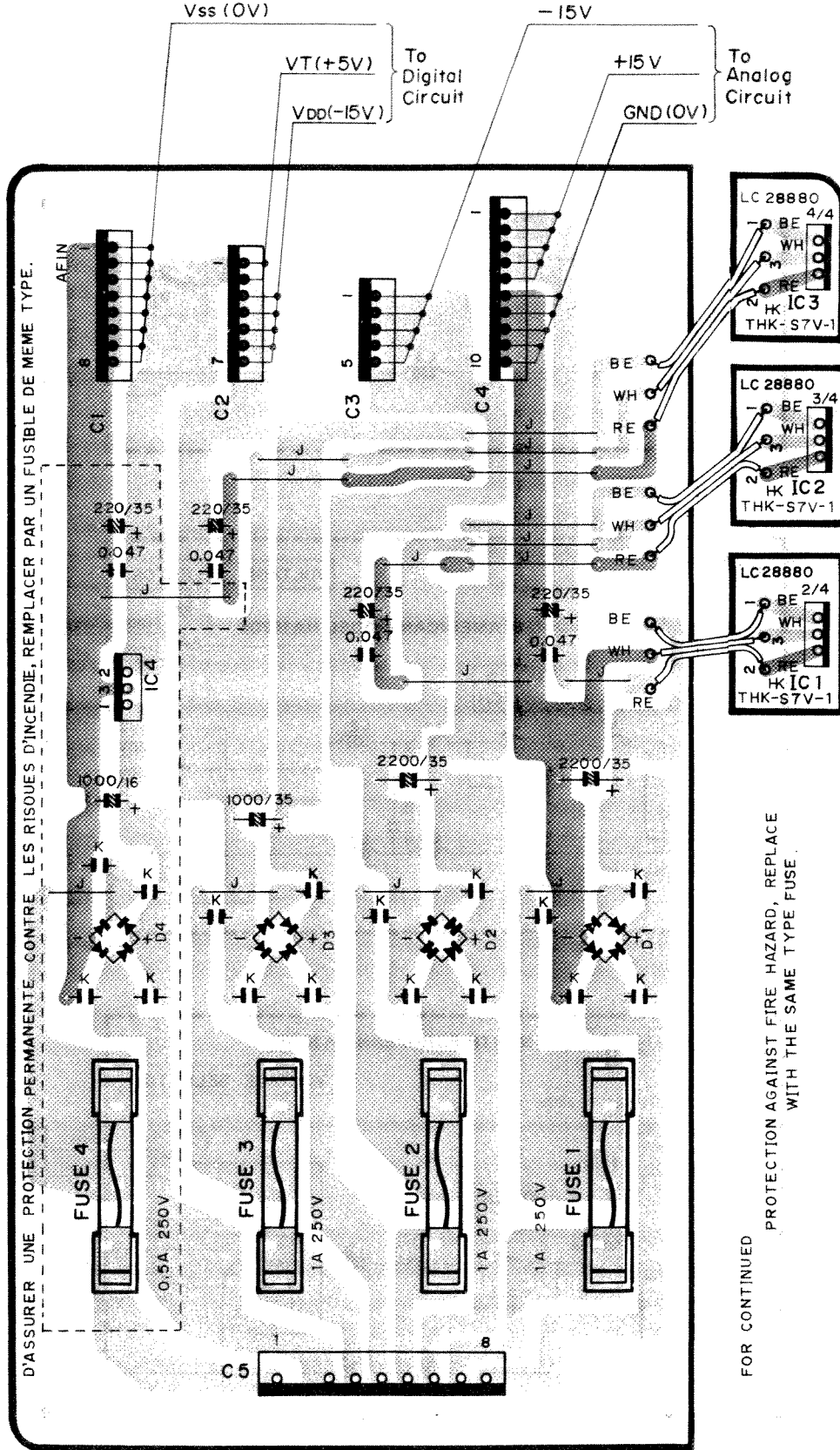

Component Side (部品側)

KEP-NA10697-14 △

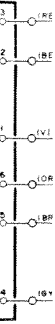

Pin No.	F
1	Vss
2	Vss
3	Vss
4	Vss
5	Vss
6	Vss
7	Vss
8	Vss

Pin No.	F
1	Vt
2	Vt
3	Vd
4	Vd
5	Vd
6	Vd
7	Vd

PANEL LAYOUT

FRONT PANEL

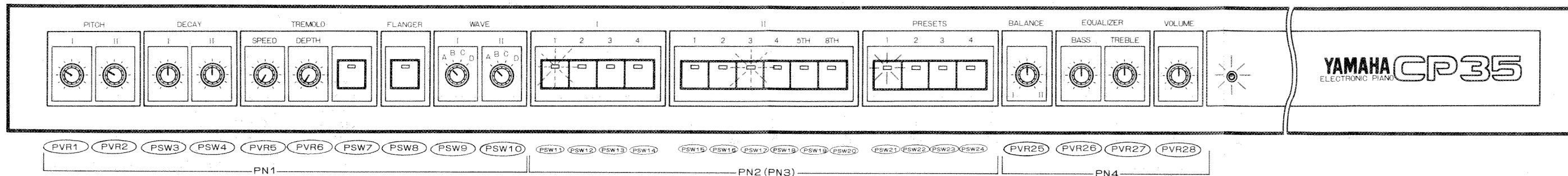

LEFT SIDE PANEL

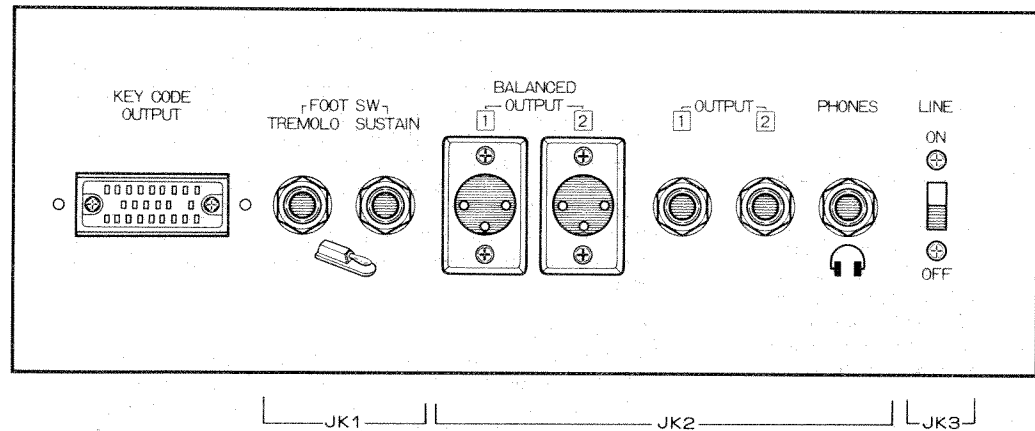

REAR PANEL

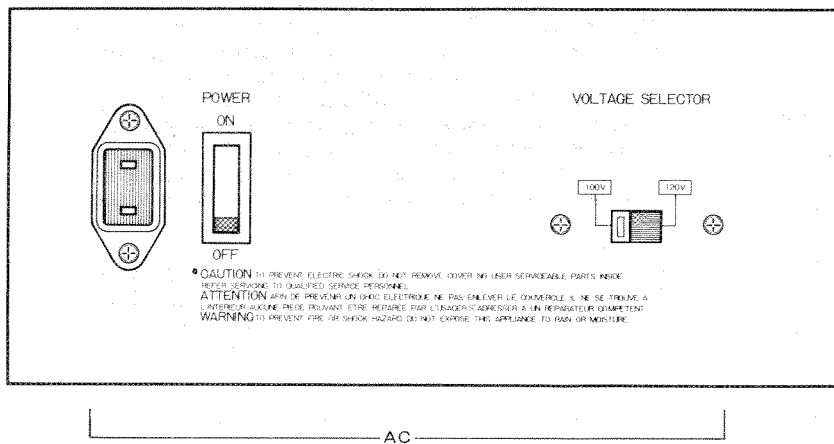

UNIT LAYOUT

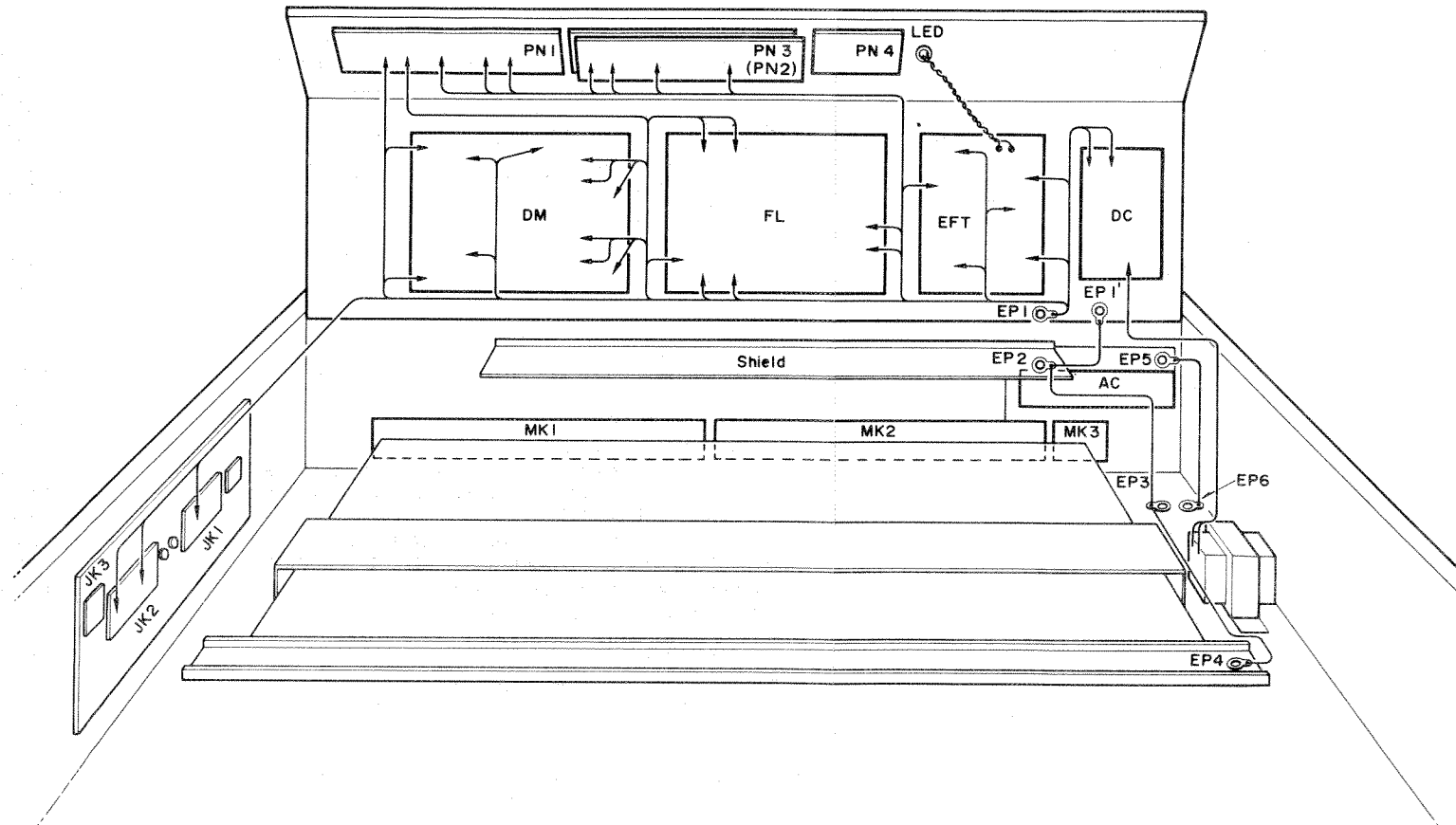

PART NAMES AND FUNCTIONS

CONTROL PANEL (FRONT PANEL)

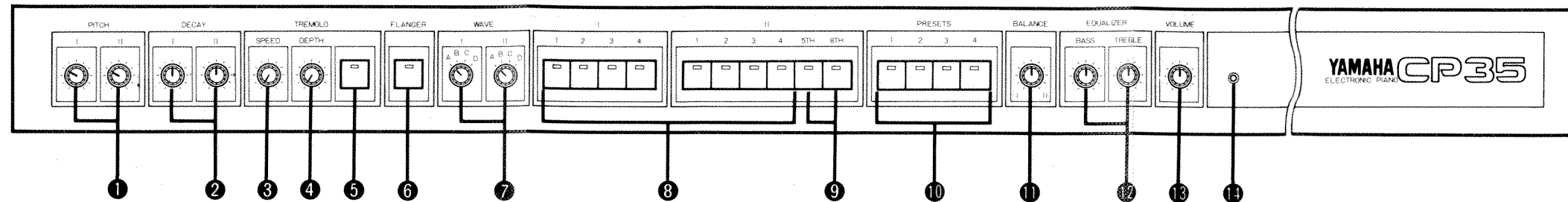
**1 PITCH I, II**

The PITCH I and PITCH II controls independently adjust the pitch of the CP35's sound channels I and II, respectively. Turning either of these controls to the right (clockwise) raises the pitch of the respective channel, while turning to the left (counterclockwise) lowers pitch.

Setting channel I and channel II to different pitches produces a "detune" effect creating a fatter, honky-tonk piano type sound.

Pitch control range is approximately from 436Hz to 453Hz. Setting the PITCH controls to approximately 10 o'clock provides 440Hz (A₃) tuning.

2 DECAY I, II

The DECAY I and DECAY II controls independently adjust the decay time of sound channels I and II, respectively. Turning either of these controls to the right (clockwise) lengthens the decay time of the respective channel, while turning to the left (counterclockwise) shortens decay time. The DECAY controls can each be set to eight different positions. Once the pitch, tone and balance of the two sound channels have been set, the DECAY I and II controls can be used to create a broad variety of decay time combinations providing extra sound control flexibility.

By setting exceptionally long decay times it is possible to create sustained, organ-like tones.

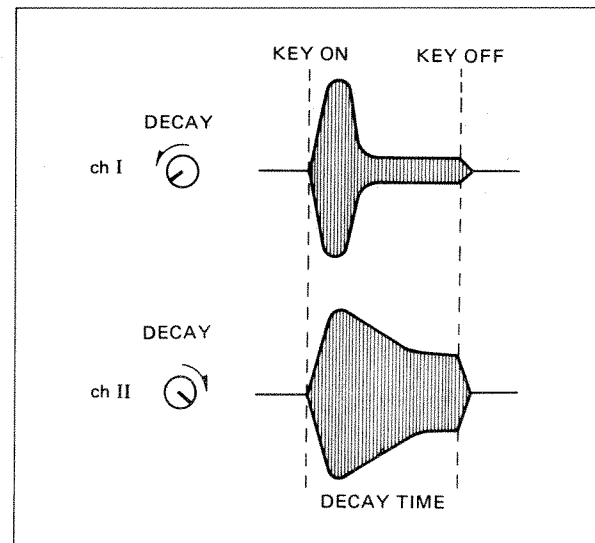
**3 TREMOLO SPEED**

The tremolo effect produces periodic variations in the volume of the sound. Turning the TREMOLO SPEED control to the right (clockwise) increases the speed of the volume variation, while turning it to the left (counterclockwise) creates a slower tremolo sound.

If the CP35's independent OUT 1 and OUT 2 outputs are connected to separate amplifier and speaker systems, the sound will seem to sweep back and forth between the two speakers at a rate determined by the TREMOLO SPEED control.

4 TREMOLO DEPTH

This control determines by how much the volume of the sound is varied by the tremolo effect. Turning the TREMOLO DEPTH control to the right (clockwise) produces a larger variation in volume, while turning it to the left (counterclockwise) produces a smaller (shallower) volume variation.

TREMOLO SPEED	TREMOLO DEPTH	TREMOLO OUTPUT
SPEED Slow	DEPTH Smaller	OUT 1
SPEED Fast	DEPTH Larger	OUT 2

5 TREMOLO SWITCH

This switch turns the tremolo effect on or off. Pressing this switch causes its LED indicator to light showing that the tremolo effect is on. Pressing it a second time turns the tremolo effect off (LED "off").

* Tremolo output from OUT 1 and 2 is reverse phase.

* If both of the tremolo outputs from OUT 1 and OUT 2 are mixed with the monaural signal by using a mixer, the tremolo effect is not produced.

6 FLANGER SWITCH

The flanger effect produces a pleasant "swooshing" or "swirling" effect with long tones, and adds interesting tonal variation to staccato passages.

Pressing the FLANGER switch causes its LED indicator to light showing that the flanger effect is on. Pressing it a second time turns the flanger effect off (LED "off").

7 WAVE I, II

The WAVE I and II selectors independently select the waveform shape of the channel I and channel II tone generators, respectively. Four different basic waveforms (A, B, C and D) can be selected for each channel, providing a broad range of subtle tonal variations.

*The WAVE selectors are only effective when the PRESETS selectors 10 are not in use.

8 FILTER I, II SELECTORS

These selectors determine the tonal quality of the sound. An independent set of four FILTER selectors is provided for each sound channel. Pressing any FILTER selector causes its LED indicator to light showing that the respective filter is activated.

- FILTER SELECTOR 1 activates a low-pass filter thereby producing a round, warm sound. Effect is the same for channel I and channel II.
- FILTER SELECTOR 2 activates a low-pass filter with a higher cutoff frequency than that of FILTER SELECTOR 1, thereby producing a somewhat harder sound. The channel I FILTER 2 selector adds an attack to the sound, while the channel II FILTER 2 selector does not.
- FILTER SELECTOR 3 activates a bandpass filter which produces a clear, well-defined sound. Effect is the same for channel I and channel II.
- FILTER SELECTOR 4 activates a high-pass filter thereby producing a hard, bright sound. The channel I FILTER 4 selector adds an attack to the sound, while the channel II FILTER 4 selector does not.

*FILTER selectors 1 through 4 (channels I and II) are only effective when the PRESETS selectors 10 are not in use. When any of the PRESETS sounds are in use, filter settings are held in "standby", and the selected filter LED's flash to indicate the standby mode. Changing filter settings while any PRESETS selector is in use causes no change in sound quality.

9 5TH, 8TH SELECTORS

These selectors raise the pitch of channel II by the designated interval with respect to channel I.

Pressing the 5th selector causes the pitch of channel II to be an interval of perfect fifth higher than channel I.

Pressing the 8th selector causes the pitch of channel II to be one octave higher than channel I.

Pressing both the 5th and 8th selectors causes the pitch of channel II to be an interval of perfect 12th (an octave and a fifth) higher than channel I.

*The 5th and 8th selectors are only effective when the PRESETS selectors 10 are not in use. When any of the PRESETS sounds are in use, 8th and 5th selector settings are held in "standby", and the selected interval LED(s) flash to indicate the standby mode.

10 PRESETS

Four preset sound selectors are provided, only one of which can be used at a time.

PRESETS have priority over the FILTER selectors, so pressing and PRESETS selector, even while the FILTER selectors are in use, immediately switches to the PRESETS sound.

- Immediate switching from the FILTER sound to the PRESETS sound is accomplished simply by pressing the desired PRESETS selector. When a PRESETS selector is pressed, active FILTER settings are held in "standby" with their respective LED indicators flashing.
- The PRESETS sounds consist of pre-programmed channel I and II WAVE, FILTER, BALANCE, and channel II 5th and 8th selector settings.

3. Controls which do affect the sound when the PRESETS are in use are PITCH, DECAY, TREMOLO, FLANGER, EQUALIZER and VOLUME.

- FILTER settings can be selected or altered while the PRESETS are in use without immediately affecting the sound. FILTER settings selected in this way are indicated by the appropriate FILTER indicator LED(s) flashing.

WAVE and BALANCE settings can also be altered in advance while the PRESETS are in use.

- Immediate switching from the PRESETS sound to the FILTER sound is accomplished by pressing the activated PRESETS selector (lighted LED) a second time.

*PRESETS selectors, PRESETS selector and FILTER selector settings cannot be combined.

In addition to the combination of FILTER I 1-4 and FILTER II 1-4, using channel I and II DECAY WAVE allows you to adjust the timbre at-will. Be sure to take advantage of the sound creation possibilities of DECAY I and II.

11 BALANCE

Determines the relative volumes of channels I and II--i.e. "mixing" between channels I and II. Turning the BALANCE control to the right (clockwise) increases the volume of channel II in relation to channel I, while turning it to the left (counterclockwise) increases the volume of channel I in relation to channel II.

*The BALANCE control is only effective when the PRESETS selectors 10 are not in use.

12 EQUALIZER

BASS: Turning the BASS control to the right (clockwise) emphasizes the low-frequency range thereby producing a fat, heavy sound. Turning this control to the left (counterclockwise) de-emphasizes the low-frequency range, while, set to its center position response is virtually flat.

TREBLE: Turning the TREBLE control to the right (clockwise) emphasizes the high-frequency range thereby producing a light, bright sound. Turning this control to the left (counterclockwise) de-emphasizes the high-frequency range, while, at its center position response is virtually flat.

13 VOLUME

Controls the overall volume level of the CP35 sound. Turning the VOLUME control to the right (clockwise) increases overall volume, while turning it to the left (counterclockwise) decreases overall volume.

14 POWER INDICATOR

This indicator lights to show that the rear-panel power switch is turned on.

BLOCK DIAGRAM

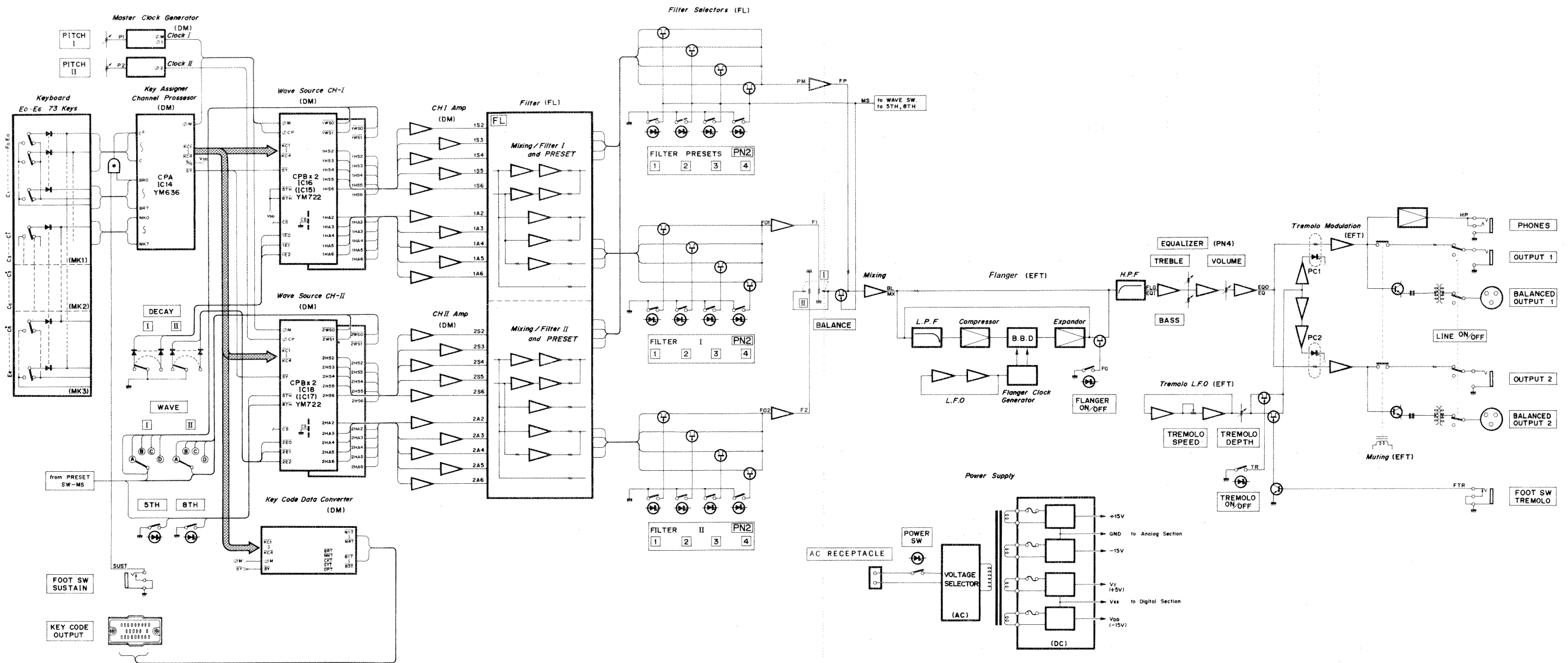

FL Circuit Diagram

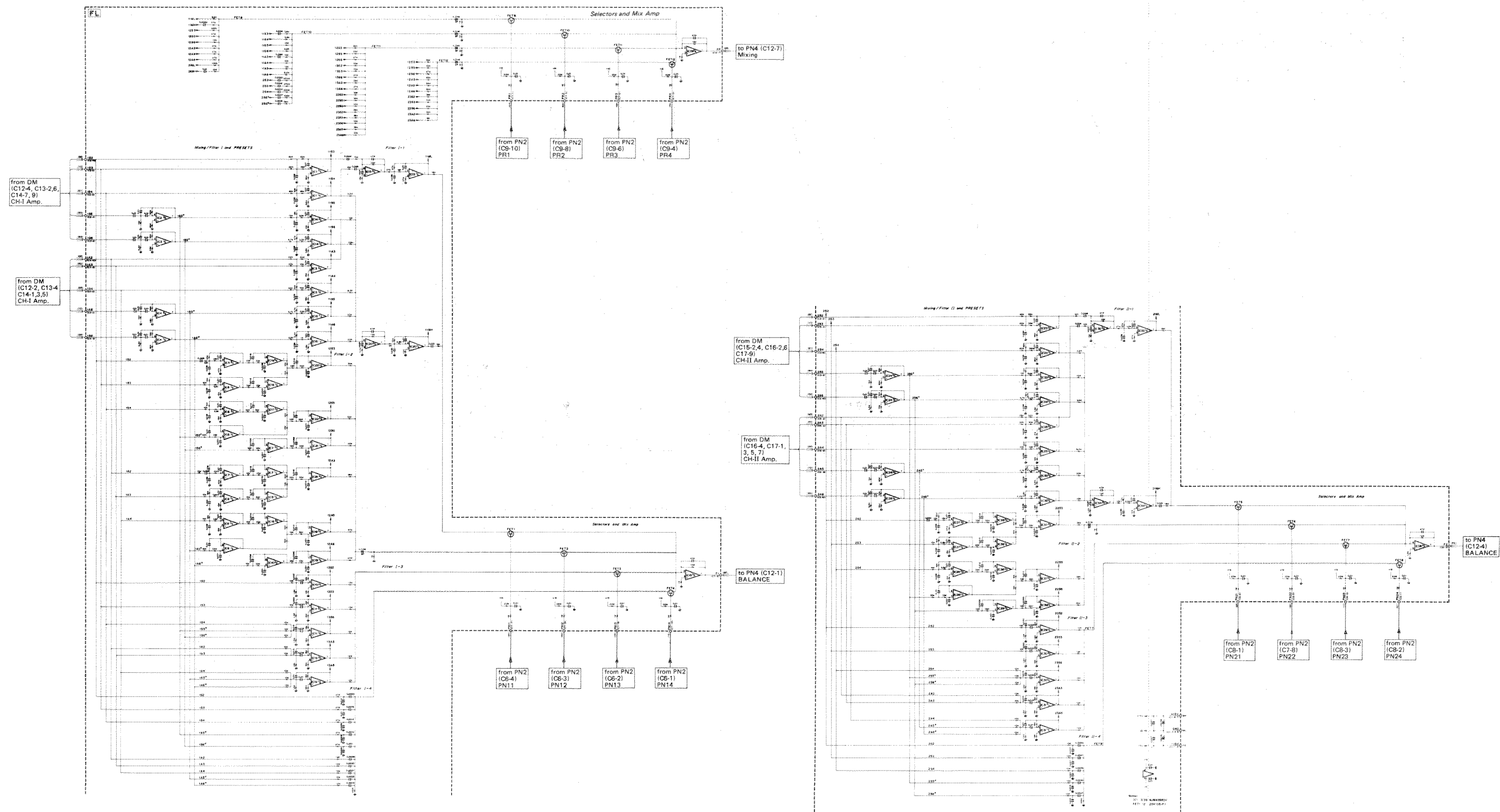

PN2, 3 Circuit Board & Wining

Pattern Side (パターン側)

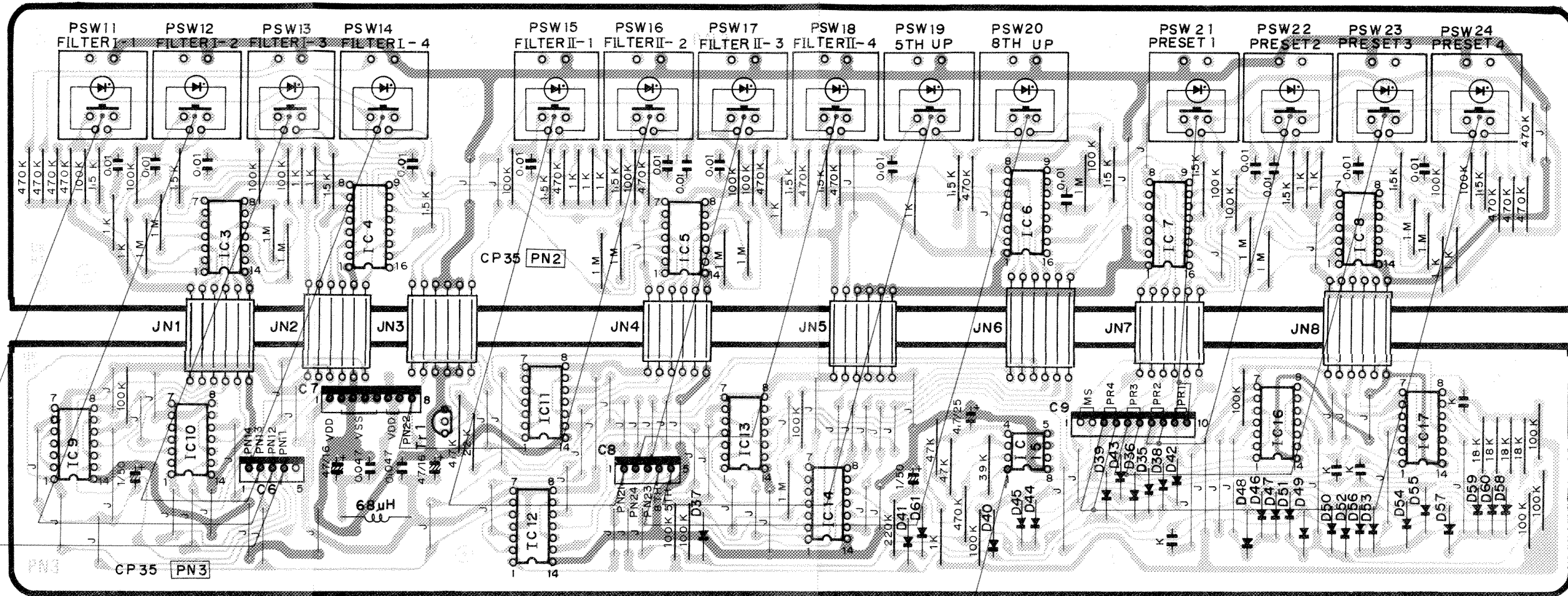

Pattern Side (パターン側)

PN3 Board

FILTER SW. Data: The levels listed below appear at the respective terminals when the FILTER switches are turned ON or OFF.

	ON	OFF
FILTER I-1→C6-4	0V	-15V
FILTER I-2→C6-3	0V	-15V
FILTER I-3→C6-2	0V	-15V
FILTER I-4→C6-1	0V	-15V

	ON	OFF
FILTER II-1→C8-1	0V	-15V
FILTER II-2→C7-8	0V	-15V
FILTER II-3→C8-3	0V	-15V
FILTER II-4→C8-2	0V	-15V
5TH →C8-5	0V	-15V
8TH →C8-4	0V	-15V

LED Flasher Circuit

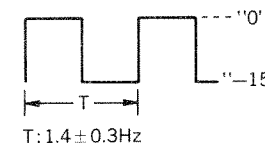

PRESET SW. Data:

The levels listed below appear at the respective terminals when the PRESET switches are turned ON or OFF.

	ON	OFF
PRESET1 (C9-9)	0V	-15V
PRESET2 (C9-7)	0V	-15V
PRESET3 (C9-5)	0V	-15V
PRESET4 (C9-3)	0V	-15V

• Connector

C6				C7				C8				C9			
Pin No.	Pin Name	Wire Color	Destination	Pin No.	Pin Name	Wire Color	Destination	Pin No.	Pin Name	Wire Color	Destination	Pin No.	Pin Name	Wire Color	Destination
1	PN14	YE	FL-PN14 (C7-10)	1	VDD ⁺	PK	PN1-VDD ⁺ (C1-6)	1	MS	BR	PN1-MS (C4-3)	1	MS	BR	PN1-MS (C4-3)
2	PN13	OR	FL-PN13 (C7-9)	2	VSS	-	-	2	MS	BR	PN1-MS (C12-5)	2	MS	BR	PN1-MS (C12-5)
3	PN12	RE	FL-PN12 (C7-8)	3	VSS	GY	PN1-VSS (C1-7)	3	PR4	PK	PN1-PR4 (C4-4)	3	PR4	PK	PN1-PR4 (C4-4)
4	PN11	BR	FL-PN11 (C7-7)	4	VSS	GY	DC-VSS (C1-3)	4	PR4	PK	FL-PR4 (C7-4)	4	PR4	PK	FL-PR4 (C7-4)
5	-	-	-	5	VSS	GY	DC-VSS (C1-4)	5	PR3	SB	PN1-PR3 (C4-5)	5	PR3	SB	PN1-PR3 (C4-5)
				6	VDD	RE	DC-VDD (C2-5)	6	PR3	SB	FL-PR3 (C7-2)	6	PR3	SB	FL-PR3 (C7-2)
				7	VDD	RE	DC-VDD (C2-6)	7	PR2	GG	PN1-PR2 (C4-6)	7	PR2	GG	PN1-PR2 (C4-6)
				8	PN22	BE	FL-PN22 (C6-5)	8	PR2	GG	FL-PR2 (C7-3)	8	PR2	GG	FL-PR2 (C7-3)
								9	PR1	WH	PN1-PR1 (C4-7)	9	PR1	WH	PN1-PR1 (C4-7)
								10	PR1	WH	FL-PR1 (C7-1)	10	PR1	WH	FL-PR1 (C7-1)

Note)

- IC
 - IC3, 5, 8, 14 : TC4081BP
 - IC4, 6, 7 : TC4049BP
 - IC9 ~ 13, 16, 17 : TC4013BP
 - IC15 : NJM4558DV
- Transistor
 - Tr1 : 2SA509 (O, Y)
- Diode
 - D35 ~ 61 : 1S1555

PN2, 3 Circuit Diagram

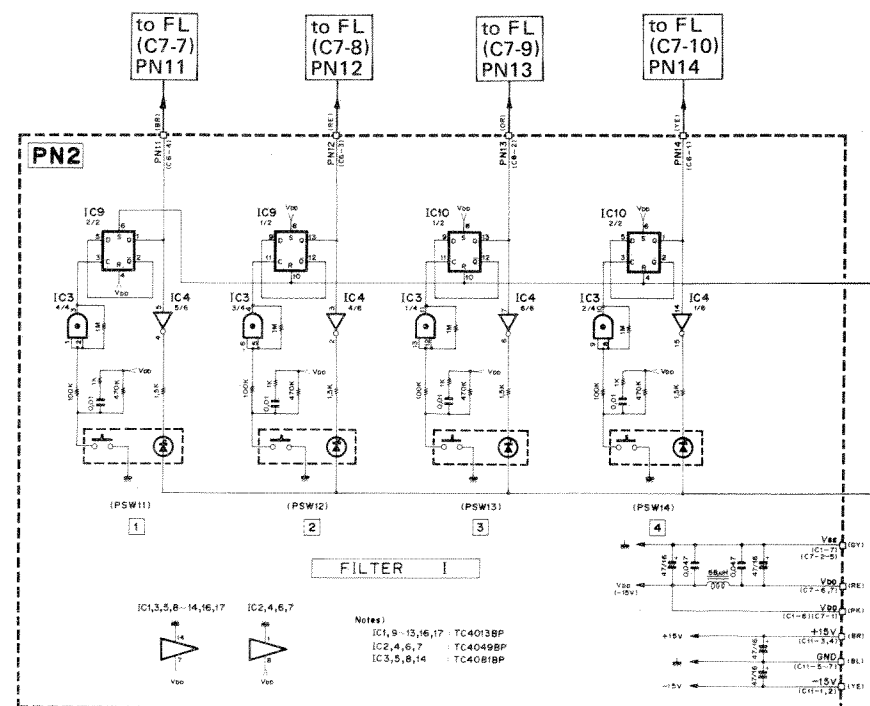
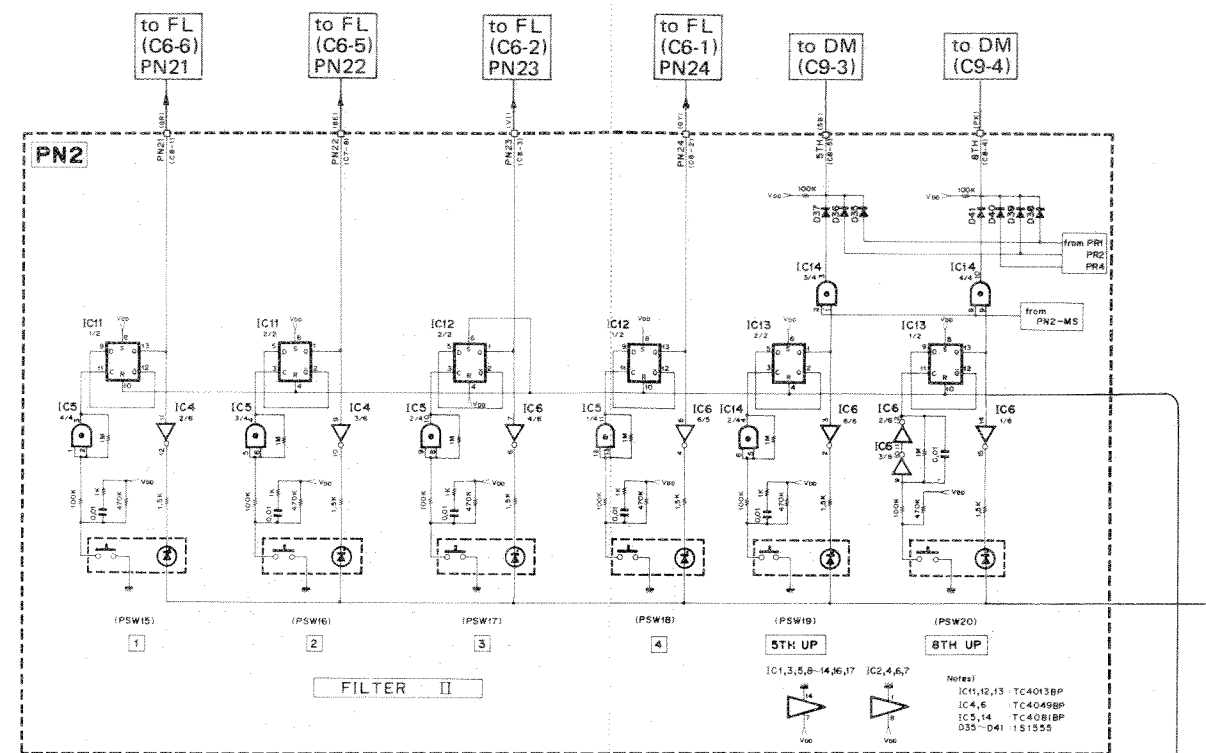
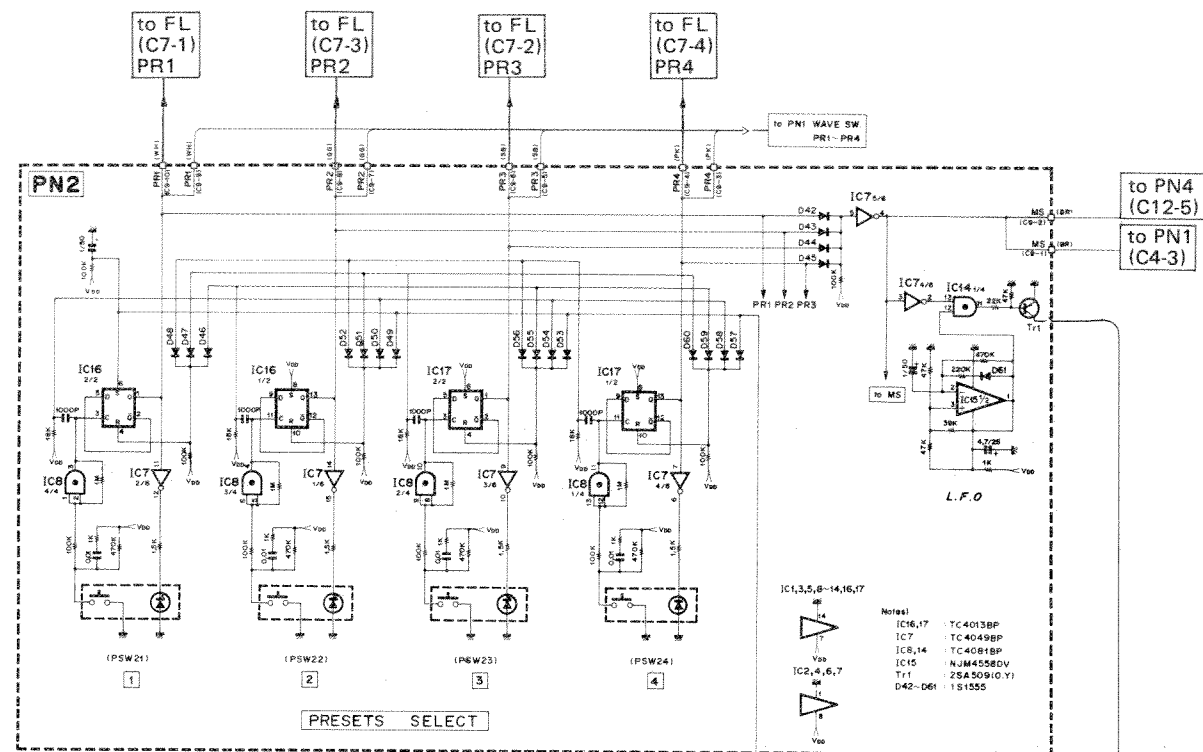

Part Name	YM636000	Function Name	CPA (Combo Piano—A) Key Coder Channel Processor
-----------	----------	---------------	--

Terminal				Terminal			
Pin No.	Name	I/O	Description	Pin No.	Name	I/O	Description
1	VSS	I	Ground (0V)	40	φM	I	Master Clock (1MHz)
2	IC	I	Initial Clear	39	VDD	I	DC Supply (-15V)
3	C#	I/O	Note Block	38	BR0	O	Octave Block (Break)
4	D	I/O	- do. -	37	MK0	O	Octave Block (Make)
5	D#	I/O	- do. -	36	BR1	O	- do. - (Break)
6	E	I/O	- do. -	35	MK1	O	- do. - (Make)
7	F	I/O	- do. -	34	BR2	O	- do. - (Break)
8	F#	I/O	- do. -	33	MK2	O	- do. - (Make)
9	G	I/O	- do. -	32	BR3	O	- do. - (Break)
10	G#	I/O	- do. -	31	MK3	O	- do. - (Make)
11	A	I/O	- do. -	30	BR4	O	- do. - (Break)
12	A#	I/O	- do. -	29	MK4	O	- do. - (Make)
13	B	I/O	- do. -	28	BR5	O	- do. - (Break)
14	C	I/O	- do. -	27	MK5	O	- do. - (Make)
15	KBT0	I	Keyboard Transposition Data No use	26	BR6	O	- do. - (Break)
16	KBT1	I	- do. -	25	MK6	O	- do. - (Make)
17	KC4	O	Key Code Data	24	BR7	O	- do. - (Break)
18	KC3	O	- do. -	23	MK7	O	- do. - (Make)
19	KC2	O	- do. -	22	8/16	I	8 Voice/16 Voice Select
20	KC1	O	- do. -	21	SY	O	Synchro Data

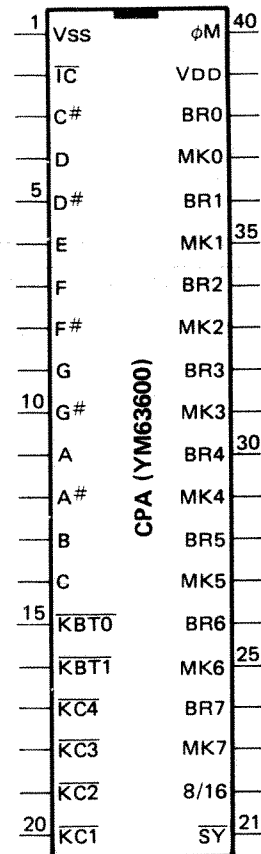

MEMO

.....

.....

.....

.....

.....

.....

.....

.....

.....

.....

• Transistor

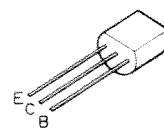

2SA509
2SA1015
2SC1815
2SC752

• FET

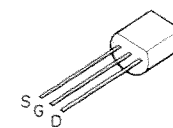

2SK105

• Diode

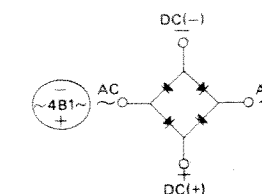

1D4B1

• IC
TC4001BP
Quadruple 2-Input NOR Gate

Logic Diagram

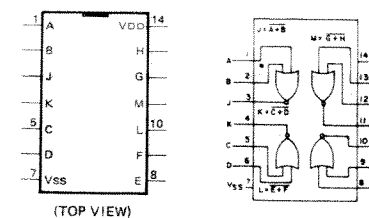

TC4011BP
Quadruple 2-Input NAND Gate

Logic Diagram

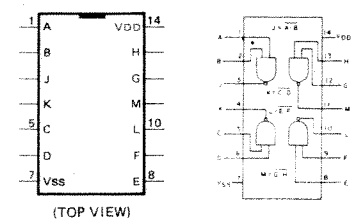

TC40174BP
Hex "D"-Type Flip-Flop

Block Diagram

Truth Tablw (1 Flip-Flop)

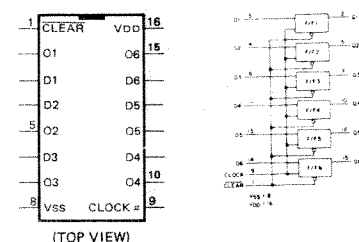

INPUTS		OUTPUT	
CLOCK	DATA	CLEAR	Q
0	0	1	0
1	1	1	1
X	X	0	NC

1 = High Level
0 = Low Level
X = Don't Care
NC = No Change

HD74LS37
Quadruple 2-Input NAND Buffers

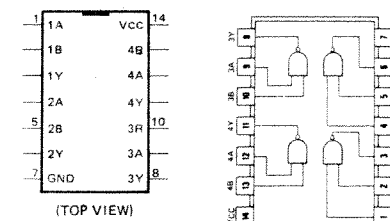

TC4013BP
Duad "D" Flip-Flop
with Set/Reset Capability

Block Diagram

Truth Table

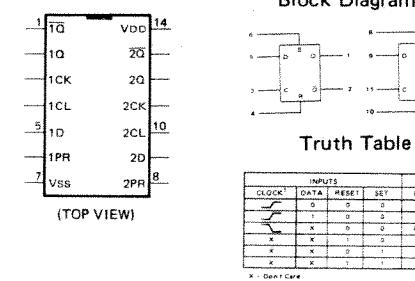

TC4049BP
Hex Buffer/Converter (Inverting)

Logic Diagram

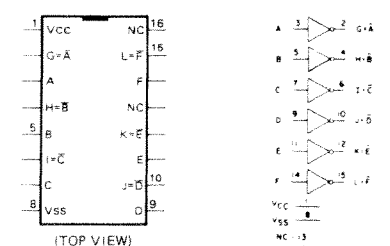

TC4081BP
Quadruple 2-Input AND Gate

Block Diagram

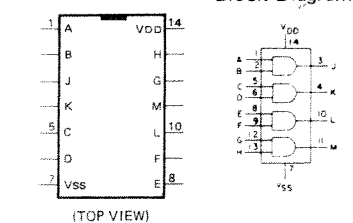

DM Circuit Board & Wining

*** KEY CODE DATA OUT**
 After power has been turned on, if the A₂ key is first pressed, then while A₂ is held F₃ is pressed, the following timing results.

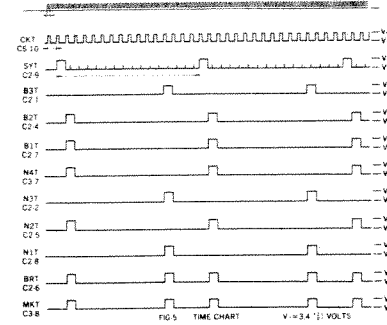

C2-3 become V_{ss} when the foot pedal is OFF.
 C2-3 become V_H-3.4 +2.1, -0.7 when the foot pedal is ON.

Key Code
 Key code is sent to a free channel in the order shown below.

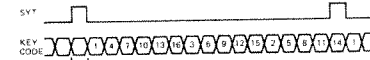

Key and Key Code Relationship
 BRT(18p) ... "H" when the transfer point (T) is not connected with the break contact (BR), "L" when the transfer point is connected to the break contact.
 MKT(19p) ... "H" when transfer point (T) is connected to the make contact (MK), "L" when envelope has ended and there is no connection with break point (BR).
 DRT(20p) ... "H" when the sustain pedal is pressed, "L" when released.
 SYT(21p) ... Synchronization signal. Synchronization=48 microseconds
 OCT(16p) ... "L" in the case of CP
 CON(17p) ... "L"
 CKT(22p) ... Clock ϕ M/3

	K2	K1
UK (CP for UK only)	L	H

* H: TTL high level (0)
 * L: TTL low level (-15)

• Connector

C1				C7				C13			
Pin No.	Pin Name	Wire Color	Destination	Pin No.	Pin Name	Wire Color	Destination	Pin No.	Pin Name	Wire Color	Destination
1	V _T	—	—	2	MKO	—	—	1	GND	—	—
2	V _T	BE	DC-V _T (C2-1)	3	BR1	GR	MK1-BR1 (C3-6)	2	1S5	S WH	FL-1S5 (C2-4)
3	V _{SS}	—	—	4	MK1	BE	MK1-MK1 (C3-7)	3	GND	—	—
4	V _{SS}	GY	DC-V _{SS} (C1-2)	5	BR2	VI	MK1-BR2 (C3-5)	4	1A2	S BR	FL-1A2 (C4-10)
5	V _{SS}	GY	DC-V _{SS} (C1-1)	6	MK2	GY	MK1-MK2 (C3-4)	5	GND	—	—
6	V _{DD}	RE	DC-V _{DD} (C2-3)	7	BR3	WH	MK1-BR3 (C3-3)	6	1S2	S SB	FL-1S2 (C2-10)
7	V _{DD}	RE	DC-V _{DD} (C2-4)	8	MK3	GG	MK1-MK3 (C3-2)	7	GND	—	—
C2				C8				C14			
Pin No.	Pin Name	Wire Color	Destination	Pin No.	Pin Name	Wire Color	Destination	Pin No.	Pin Name	Wire Color	Destination
1	B3T	BR	KC-B3T (CN-3)	1	BR5	BR	MK2-BR5 (C3-5)	1	1A5	S YE	FL-1A5 (C4-4)
2	N3T	GR	KC-N3T (CN-7)	2	MK5	RE	MK2-MK5 (C3-4)	2	GND	—	—
3	DPT	SB	KC-DPT (CN-20)	3	BR6	OR	MK2-BR6 (C3-3)	3	1A6	S GR	FL-1A6 (C4-2)
4	B2T	RE	KC-B2T (CN-4)	4	MK6	YE	MK2-MK6 (C3-2)	4	GND	—	—
5	N2T	BE	KC-N2T (CN-8)	5	BR7	GR	MK3-BR7 (C1-2)	5	1A3	S RE	FL-1A3 (C4-8)
6	BRT	GY	KC-BRT (CN-18)	6	MK7	BE	MK3-MK7 (C1-3)	6	GND	—	—
7	B1T	OR	KC-B1T (CN-5)	7	MK7	—	—	7	1S3	S VI	FL-1S3 (C2-8)
8	N1T	VI	KC-N1T (CN-9)	8	CKT	SB	KC-CKT (CN-22)	8	GND	—	—
9	SYT	PK	KC-SYT (CN-21)					9	1S6	S GG	FL-1S6 (C2-2)
10	CKT	SB	KC-CKT (CN-22)					10	GND	—	—
C3				C9				C15			
Pin No.	Pin Name	Wire Color	Destination	Pin No.	Pin Name	Wire Color	Destination	Pin No.	Pin Name	Wire Color	Destination
1	V _{SS} *	WH	KC-V _{SS} * (CN-23)	1	ZWS0	WH	PN1-ZWS0 (C5-2)	1	GND	—	—
2	V _{SS} *	WH	KC-V _{SS} * (CN-24)	2	ZWS1	GG	PN1-ZWS1 (C5-5)	2	ZS3	S VI	FL-2S3 (C3-4)
3	CON	WH	KC-CON (CN-16)	3	BTR	SB	PN3-BTR (C8-5)	3	GND	—	—
4	OCT	WH	KC-OCT (CN-17)	4	BTR	PK	PN3-BTR (C8-4)	4	ZS6	S GG	FL-2S6 (C3-10)
5	K2	WH	KC-K2 (CN-1)	5	ZE0	YE	PN1-ZE0 (C2-5)	5	GND	—	—
6	K1	VI	KC-K1 (CN-2)	6	ZE1	GR	PN1-ZE1 (C2-6)				
7	N4T	YE	KC-N4T (CN-6)	7	ZE2	BE	PN1-ZE2 (C2-7)				
8	MKT	GG	KC-MKT (CN-19)	8	SUST	BR	JK-SUST (C1-5)				
C4				C10				C16			
Pin No.	Pin Name	Wire Color	Destination	Pin No.	Pin Name	Wire Color	Destination	Pin No.	Pin Name	Wire Color	Destination
1	V _{SS} *	—	—	1	TE0	BR	PN1-TE0 (C2-2)	1	GND	—	—
2	P1	SB	PN1-P1 (C1-1)	2	TE1	RE	PN1-TE1 (C2-3)	2	ZS4	S GY	FL-2S4 (C3-6)
3	V _{SS} *	WH	PN1-V _{SS} (C1-2)	3	TE2	OR	PN1-TE2 (C2-4)	3	GND	—	—
4	P2	PK	PN1-P2 (C1-4)	4	1WS1	GY	PN1-1WS1 (C5-3)	4	2A2	S BR	FL-2A2 (C5-2)
5	V _{DD} *	OR	PN1-V _{DD} * (C1-3)	5	1WS0	VI	PN1-1WS0 (C5-4)	5	GND	—	—
C5				C11				C17			
Pin No.	Pin Name	Wire Color	Destination	Pin No.	Pin Name	Wire Color	Destination	Pin No.	Pin Name	Wire Color	Destination
1	C#	BR	MK1-C# (C1-7)	1	-15V	—	—	1	2A5	S YE	FL-2A5 (C5-8)
2	D	RE	MK1-D (C1-6)	2	-15V	YE	DC-15V (C3-1)	2	GND	—	—
3	D#	OR	MK1-D# (C1-5)	3	GND	—	—	3	2A6	S GR	FL-2A6 (C5-10)
4	E	YE	MK1-E (C1-4)	4	GND	BL	DC-GND (C4-6)	4	GND	—	—
5	F	GR	MK1-F (C1-3)	5	GND	BL	FL-GND (C1-5)	5	2A3	S RE	FL-2A3 (C5-4)
6	F#	BE	MK1-F# (C1-2)	6	+15V	—	—	6	GND	—	—
7	G	VI	MK1-G (C1-1)	7	+15V	BR	DC+15V (C4-1)	7	2A4	S OR	FL-2A4 (C5-6)
C6				C12							
Pin No.	Pin Name	Wire Color	Destination	Pin No.	Pin Name	Wire Color	Destination				
1	G#	GY	MK1-G# (C2-5)	1	GND	—	—				
2	A#	WH	MK1-A# (C2-4)	2	1A4	S OR	FL-1A4 (C4-6)				
3	A#	GG	MK1-A# (C2-3)	3	GND	—	—				
4	B	SB	MK1-B (C2-2)	4	1S4	S GY	FL-1S4 (C2-6)				
5	C	PK	MK1-C (C2-1)	5	GND	—	—				

- Note)
- IC
 - IC1 ~ 3 : HD74LS37
 - IC4 : TC4011BP
 - IC5, 6 : TC4013BP
 - IC7 : TC4001BP
 - IC8 ~ 11 : TC40174BP
 - IC12, 13 : TC4081BP
 - IC14 : YM636
 - IC15 ~ 18 : YM722
 - IC19 ~ 28 : NJM4558DV
 - Transistor
 - Tr1 ~ 10 : 2SC752 (Y)
 - Tr11 : 2SA509Y
 - Diode
 - D1 ~ 27 : 1S1555

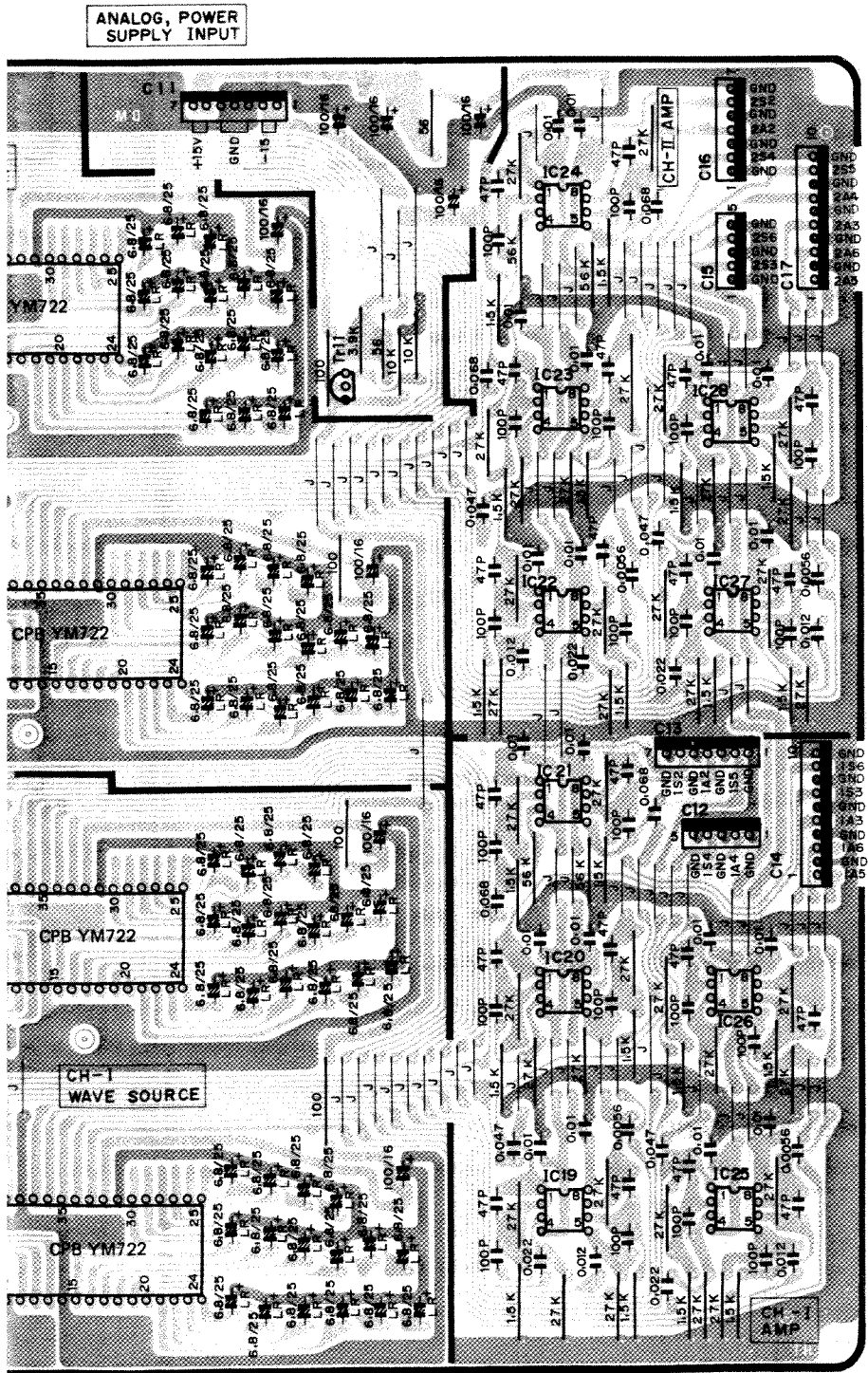

DM Circuit Diagram

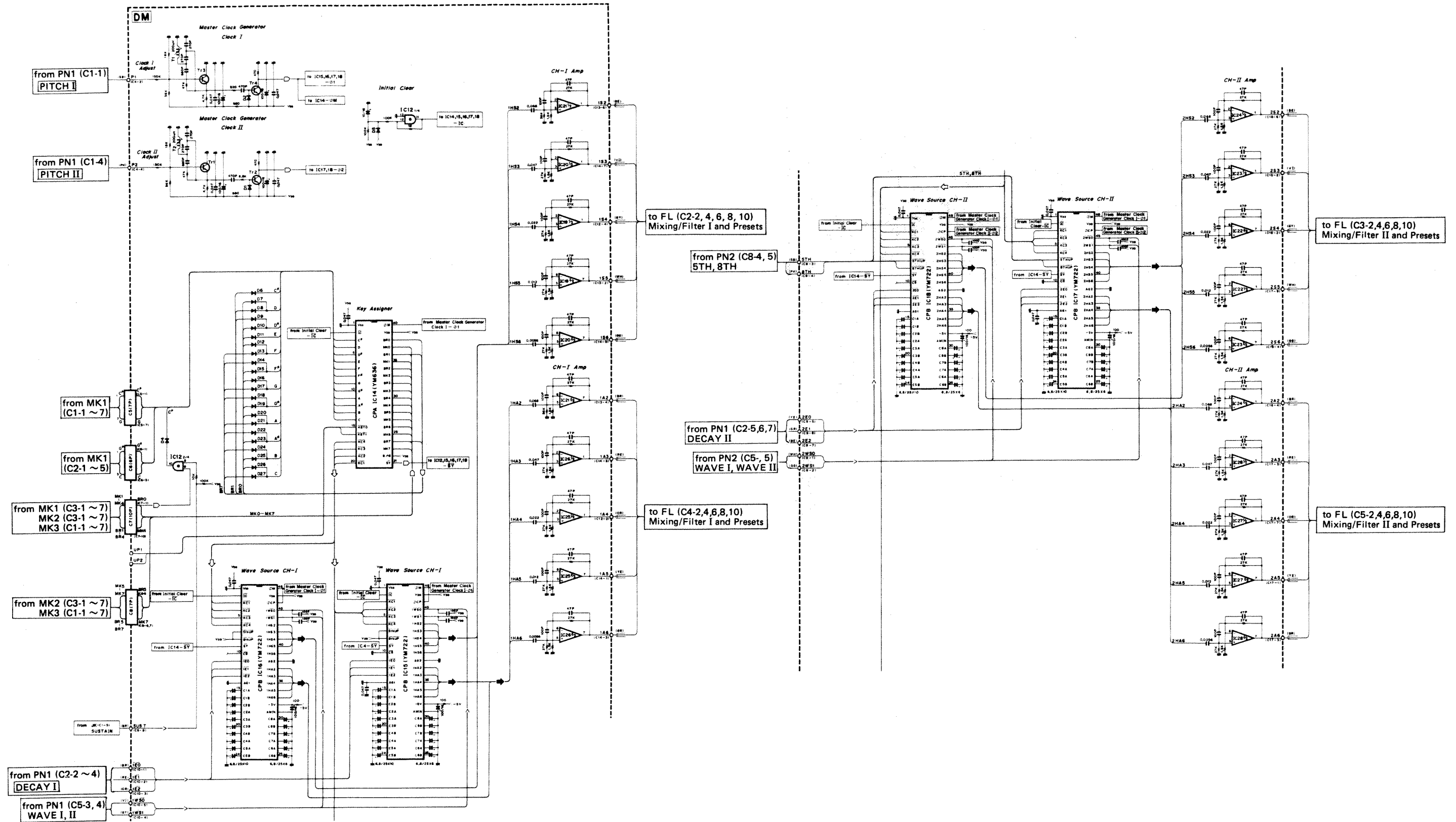

EFT Circuit Diagram

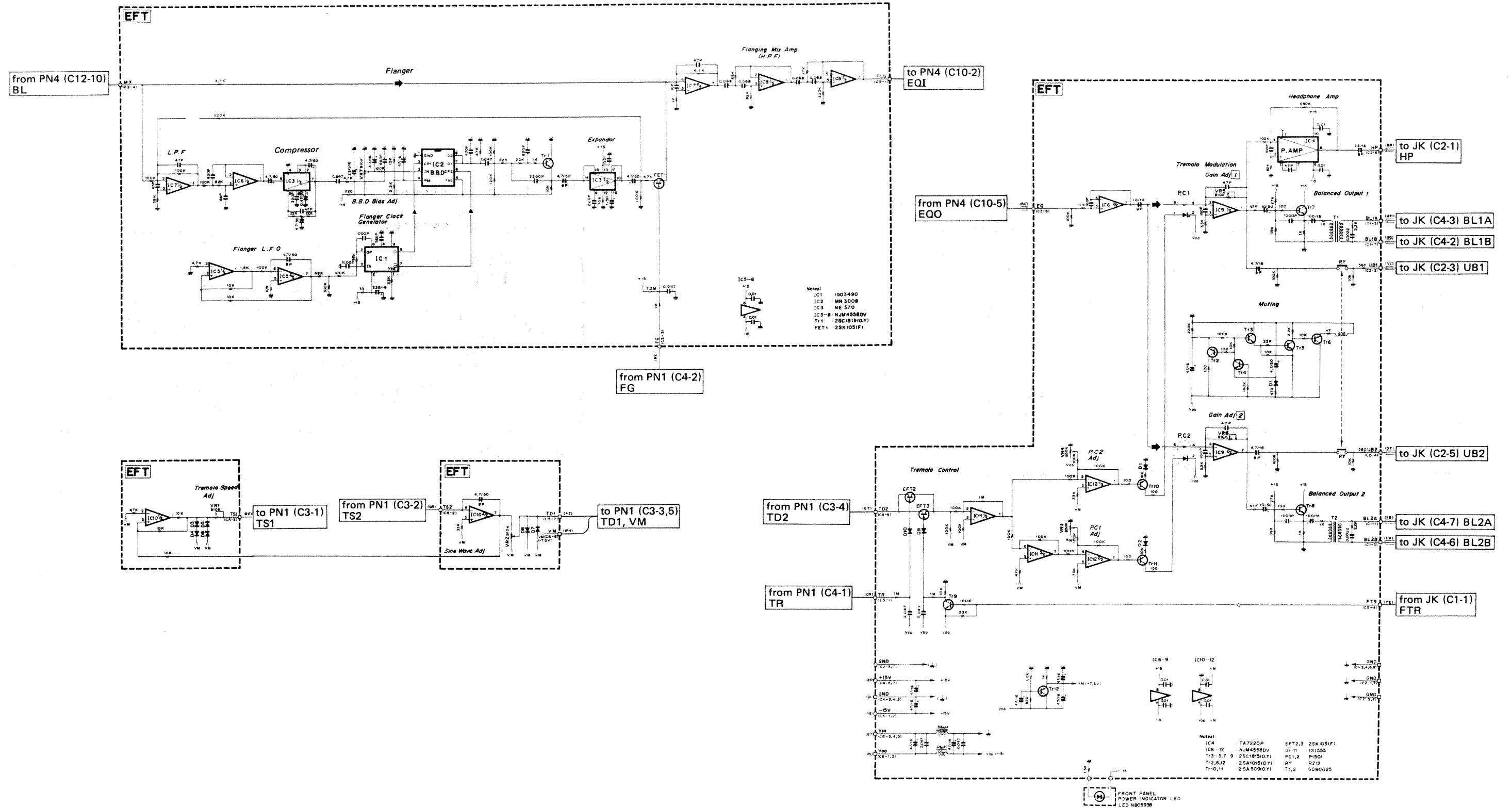

PN1, 4 Circuit Board & Wiring

WAVE SELECT Data

PRESET SW. PSW21, 22, 23, 24 Wave Select Data PRESET SW 'ON'

PRESET 'ON' POSITION	PR1 (C4-7)	PR2 (C4-6)	PR3 (C4-5)	PR4 (C4-4)	1WS1 (C5-3)	1WS0 (C5-4)	2WS1 (C5-5)	2WS0 (C5-2)
1	V _{SS}	V _{DD}	V _{DD}	V _{DD}	H	L	H	H
2	V _{DD}	V _{SS}	V _{DD}	V _{DD}	H	H	H	H
3	V _{DD}	V _{DD}	V _{SS}	V _{DD}	L	H	H	H
4	V _{DD}	V _{DD}	V _{DD}	V _{SS}	H	L	H	L

"V_{SS}"="H"="0 v"
"V_{DD}"="L"="-15 v"

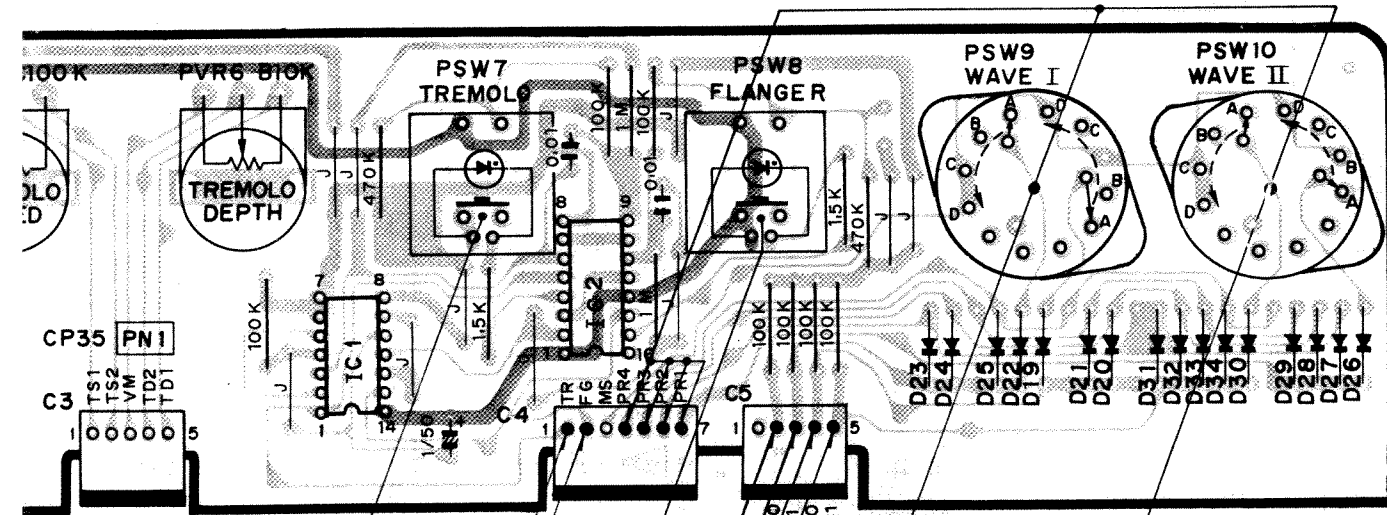

TREMOLO SW. "ON"=0V "OFF"=-15V
FLANGER SW. "ON"=0V "OFF"=-15V

WAVE SW. PSW9, 10 Data PRESET SW. 'OFF'

WAVE SW. POSITION	1WS1 (C5-3)	1WS0 (C5-4)	2WS1 (C5-5)	2WS0 (C5-2)
A	L	L		
B	L	H		
C	H	L		
D	H	H		

C5

Pin No.	Pin Name	Wire Color	Destination
1	TS1	VM	DM-2WS0 (C9-1)
2	TS2	VM	DM-1WS1 (C10-4)
3	TS3	VI	DM-1WS0 (C10-5)
4	TS4	VI	DM-1WS0 (C10-5)
5	TS5	GG	DM-2WS1 (C9-2)

- Notes
- IC
IC1 : TC4013BP
IC2 : TC4049BP
 - Diode
D1 ~ 34 : 1S1555

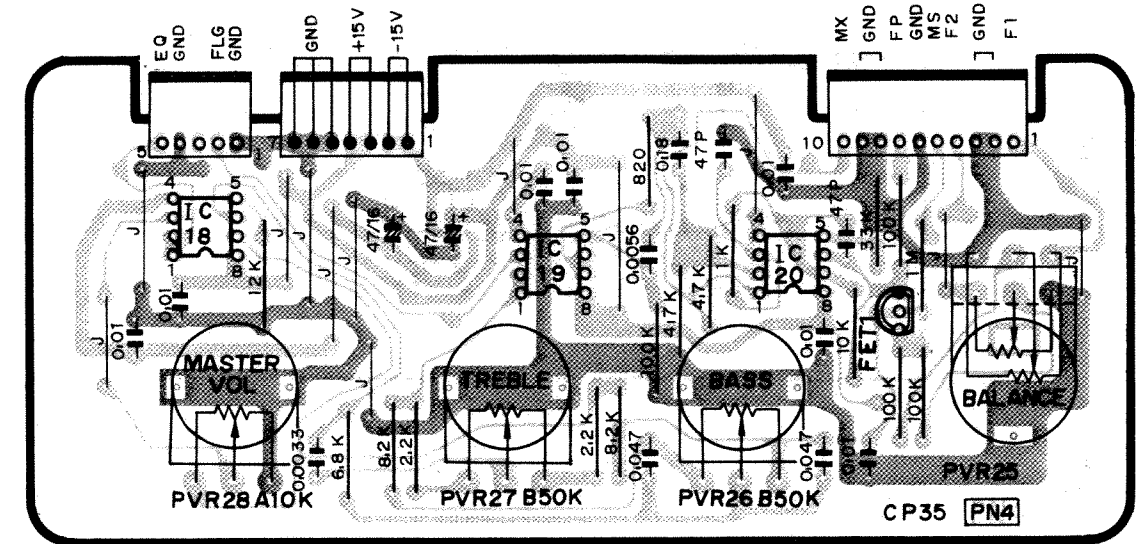

Pattern Side (パターン側)

● Connector

C10

Pin No.	Pin Name	Wire Color	Destination
1	GND	S GR S	-
2	FLG	S GR	EFT-FLG (C3-1)
3	-	-	-
4	GND	-	-
5	EQ	S BE	EFT-EQ (C3-6)

C11

Pin No.	Pin Name	Wire Color	Destination
1	-15V	YE	DC-15V (C3-5)
2	-15V	YE	EFT-15V (C4-2)
3	+15V	BR	DC+15V (C4-5)
4	+15V	BR	EFT+15V (C4-7)
5	GND	-	-
6	GND	BL	DCGND (C4-9)
7	GND	BL	EFT-GND (C4-6)

C12

Pin No.	Pin Name	Wire Color	Destination
1	F1	S RE	FL-F1 (C7-5)
2	GND	S RE	-
3	GND	S BR	-
4	F2	S BR	FL-F2 (C6-3)
5	MS	BR	PN3-MS (C9-2)
6	GND	S OR S	-
7	FP	S OR	FL-FP (C6-7)
8	GND	-	-
9	GND	-	-
10	MX	S YE	EFT-MX (C3-4)

- Note)
- IC
IC1 ~ 39 : NJM4558DV
 - FET
FET1 ~ 12 : 2SK105 (F)

PN1 Circuit Diagram

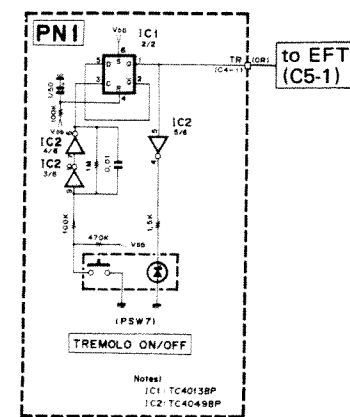
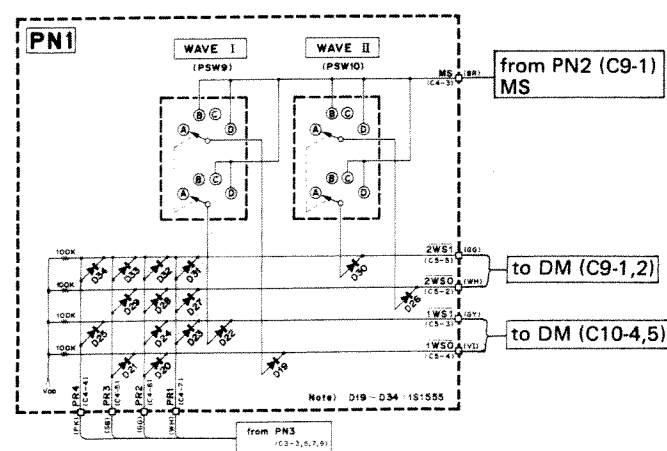
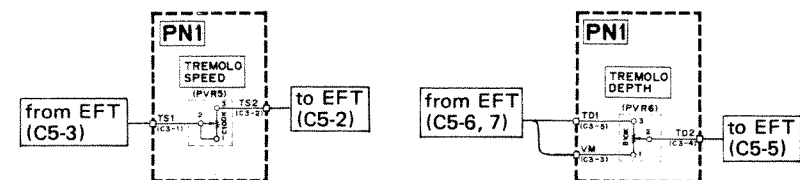
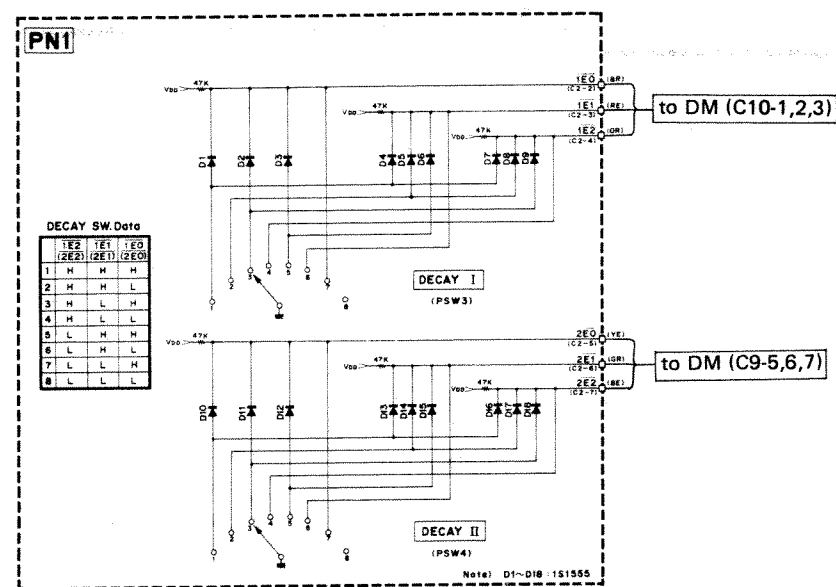
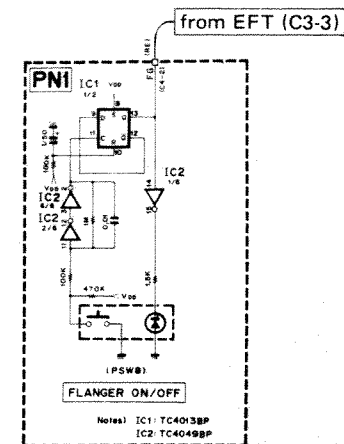
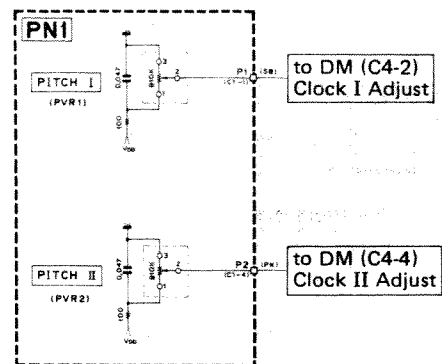

MK1, 2, 3 Circuit Board & Wiring, Circuit Diagram

C3

Pin	7	6	5	4	3	2	1
MK1	MK1	BR1	BR2	MK2	BR3	MK3	MK3
(MK2)	MK4	BR4	BR5	MK5	BR6	MK6	MK6

C4

Pin	7	6	5	4	3	2	1
MK1	C#	D	D#	E	F	F#	G
(MK2)	C#	D	D#	E	F	F#	G

C5

Pin	5	4	3	2	1
MK1	G#	A	A#	B	C
MK2	-	-	-	-	-

Pin	7	6	5	4	3	2	1
MK3	C#	D	D#	E	MK7	BR7	BR7

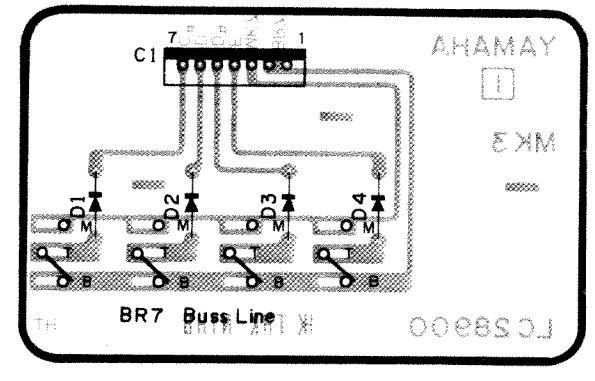
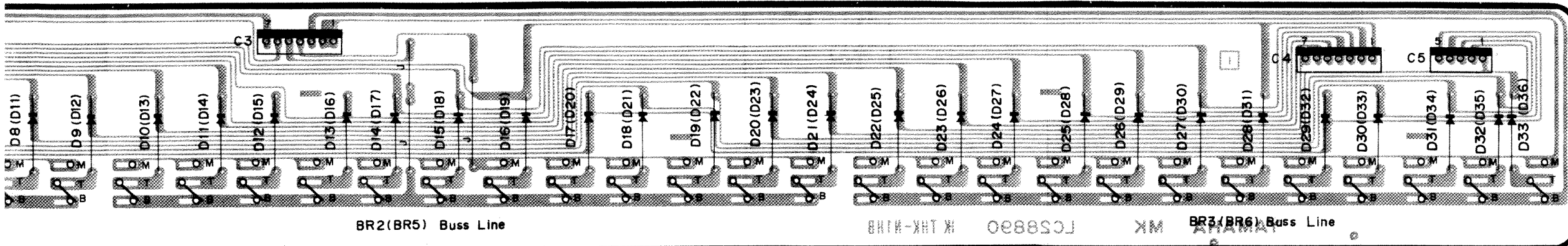

Bo C1 C# D1 D# E1 F1 F# G1 G# A1 A# B1 C2 C# D2 D# E2 F2 F# G2 G# A2 A# B2 C3
 (B3) (C4) (C4) (D4) (D4) (E4) (F4) (F4) (G4) (G4) (A4) (A4) (B4) (C5) (C5) (D5) (D5) (E5) (F5) (F5) (G5) (G5) (A5) (A5) (B5) (C6)

KEP-NA10700-13

KEP-NA10702-13

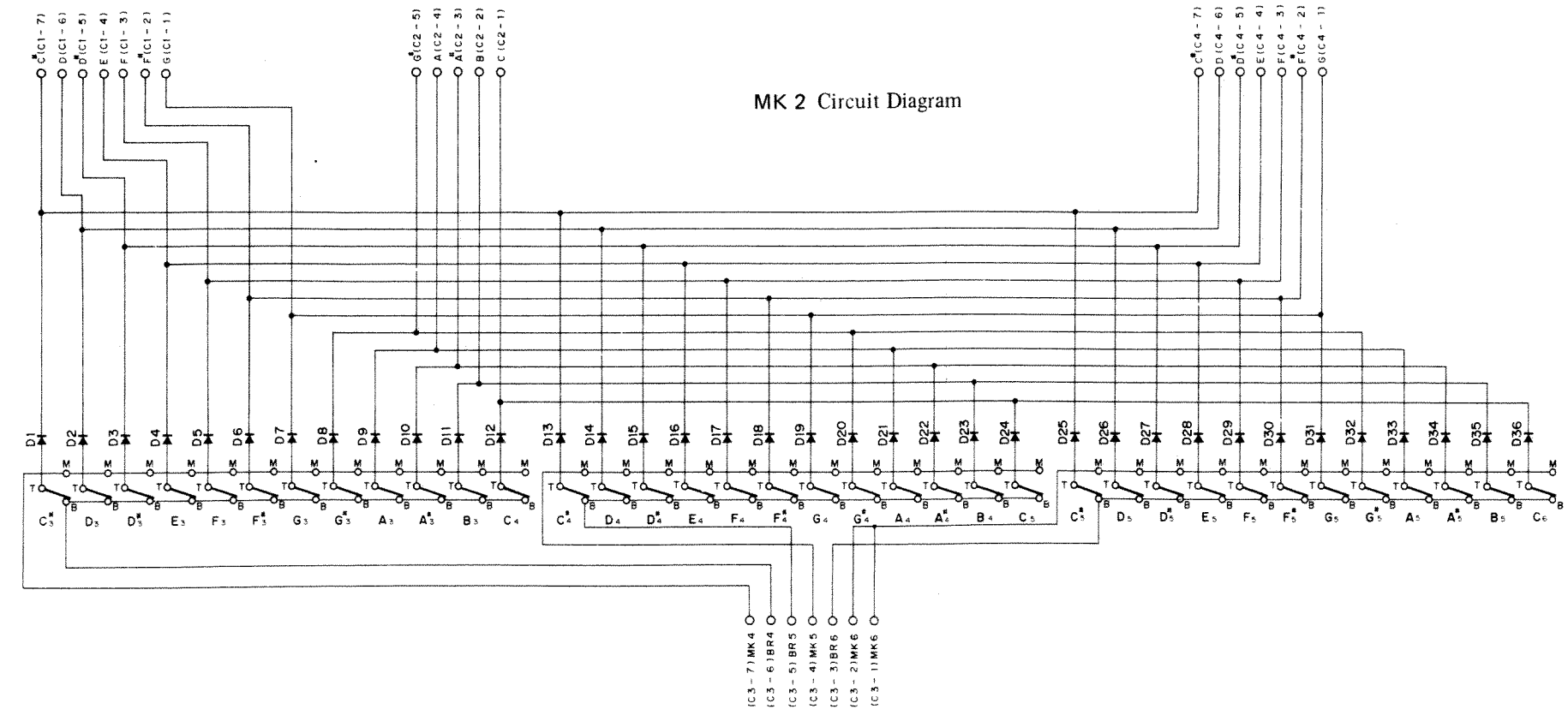
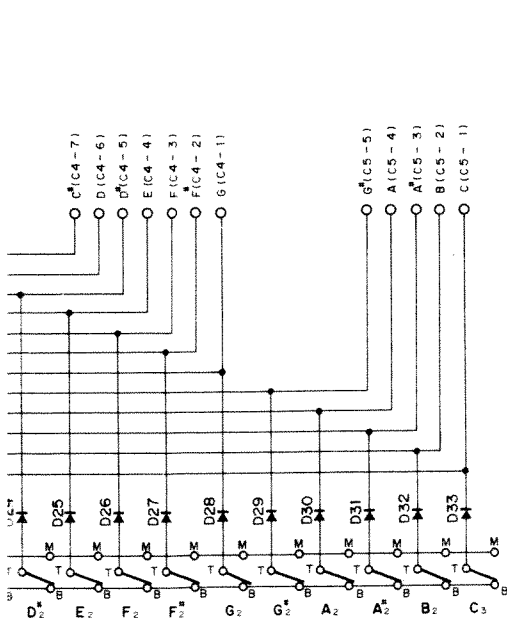

- Notes)
- MK1 Board
 - Diodes D1 ~ 33 : 1S1555
 - MK2 Board
 - Diodes D1 ~ 36 : 1S1555
 - MK3 Board
 - Diodes D1 ~ 4 : 1S1555

JK1, 2, 3, Circuit Board & Wining, Circuit Diagram

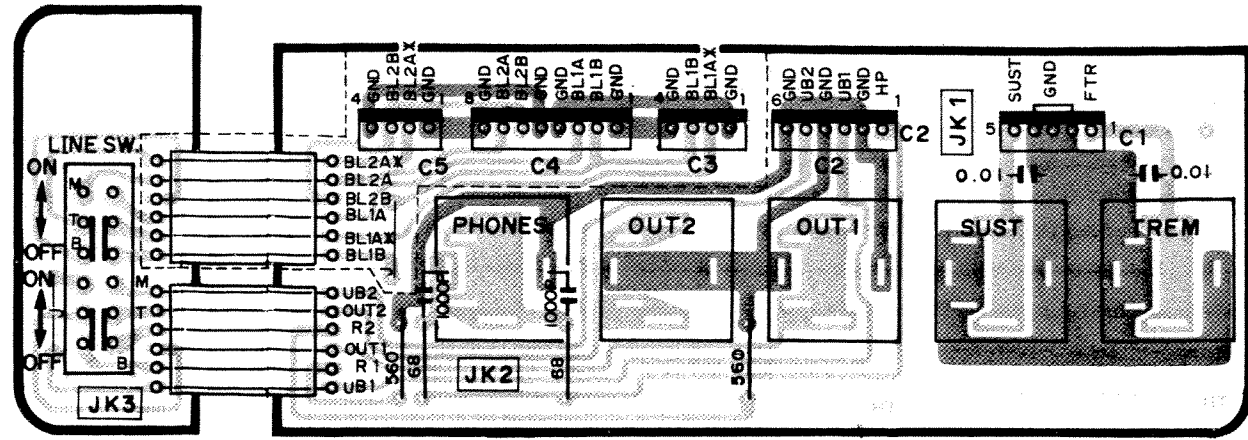

Pattern Side (パターン側)

• Connector

KEP-NA10696-17 △

C1

Pin No.	Pin Name	Wire Color	Destination
1	FTR	YE	EFT-FTR (C5-4)
2	GND	-	-
3	GND	BL	EFT-GND (C2-1)
4	GND	-	-
5	SUST	BR	DM-SUST. (C9-8)

C2

Pin No.	Pin Name	Wire Color	Destination
1	HP	S BR	EFT-HP (C2-6)
2	GND	S BR	EFT-GND (C2-7)
3	UB1	S VI	EFT-UB1 (C2-3)
4	GND	S VI	EFT-GND (C2-3)
5	UB2	S GY	EFT-UB2 (C2-4)
6	GND	S GY	EFT-GND (C2-5)

C3

Pin No.	Pin Name	Wire Color	Destination
1	GND	S OR	XLR1-GND (XLR1-1)
2	BL1A*	S OR	XLR1-BL1A* (XLR1-2)
3	BL1B	S YE	XLR1-BL1B (XLR1-3)
4	GND	S YE	XLR1-GND (XLR1-1)

C4

Pin No.	Pin Name	Wire Color	Destination
1	GND	S GG	EFT-GND (C1-8)
2	BL1B	S GG	EFT-BL1B (C1-7)
3	BL1A	S WH	EFT-BL1A (C1-6)
4	GND	S WH	EFT-GND (C1-6)
5	GND	S PK	EFT-GND (C1-4)
6	BL2B	S PK	EFT-BL2B (C1-3)
7	BL2A	S SB	EFT-BL2A (C1-1)
8	GND	S SB	EFT-GND (C1-2)

C5

Pin No.	Pin Name	Wire Color	Destination
1	GND	S OR	XLR-GND (XLR2-1)
2	BL2A*	S OR	XLR2-BL2A* (XLR2-2)
3	BL2B	S YE	XLR2-BL2B (XLR2-3)
4	GND	S YE	XLR2-GND (XLR2-1)

XLR1

Pin No.	Pin Name	Wire Color	Destination
1	GND	S OR	JK-GND (C3-1)
1	GND	S YE	JK-GND (C3-4)
2	BL1A*	S OR	JK-BL1A* (C3-2)
3	BL1B	S YE	JK-BL1B (C3-3)

XLR2

Pin No.	Pin Name	Wire Color	Destination
1	GND	S OR	JK-GND (C5-1)
1	GND	S YE	JK-GND (C5-4)
2	BL2A*	S OR	JK-BL2A* (C5-2)
3	BL2B	S YE	JK-BL2B (C5-3)

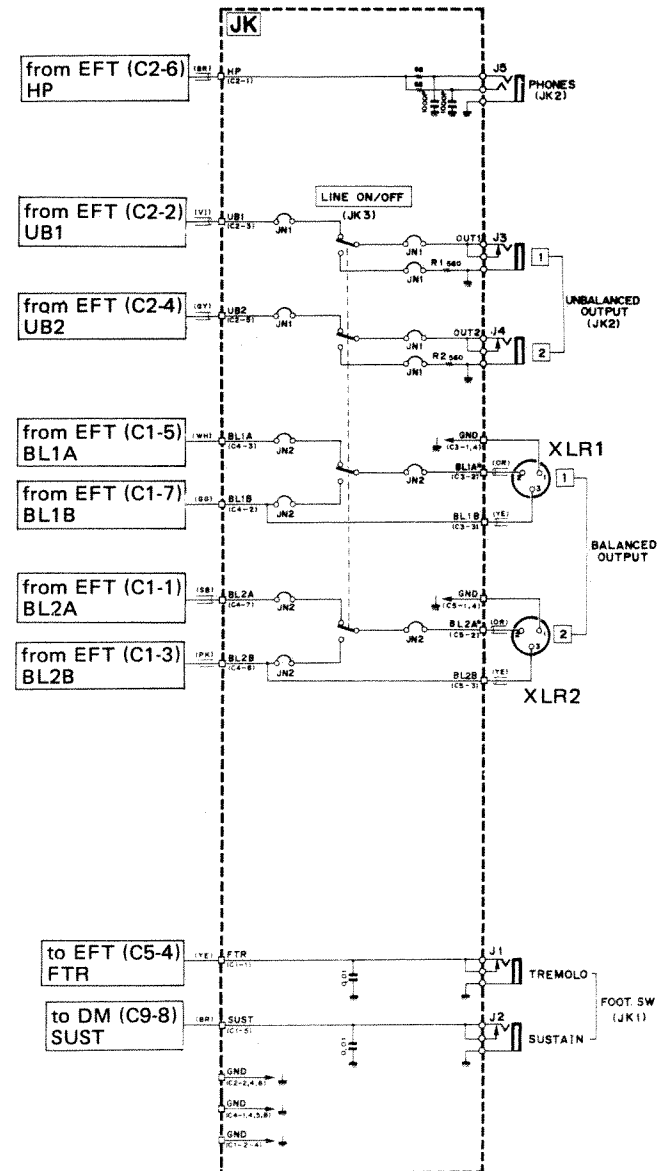

KEC-10173-13 △

• Japanese, Canadian model

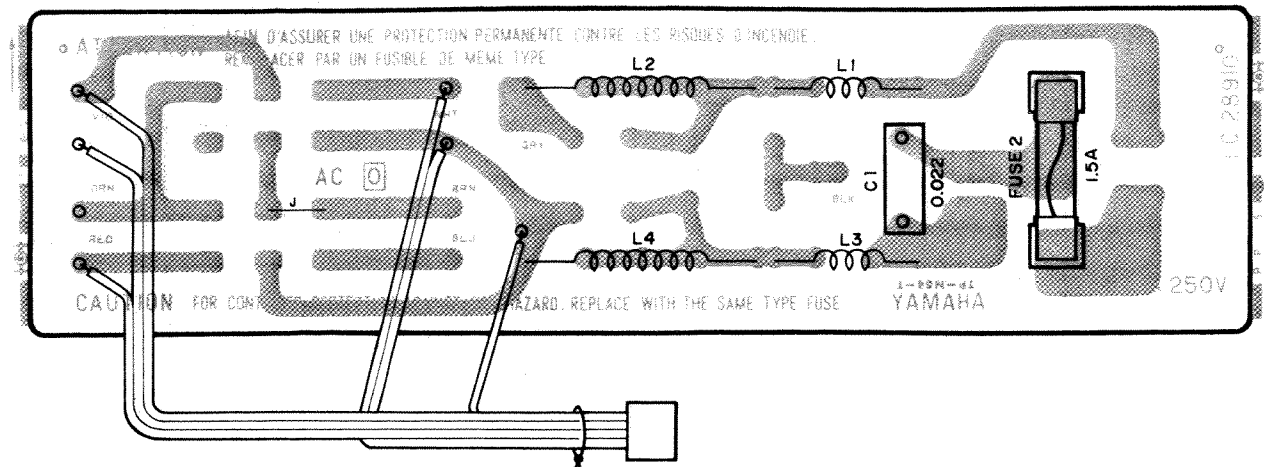

Pattern Side (パターン側)

• U.S. American model

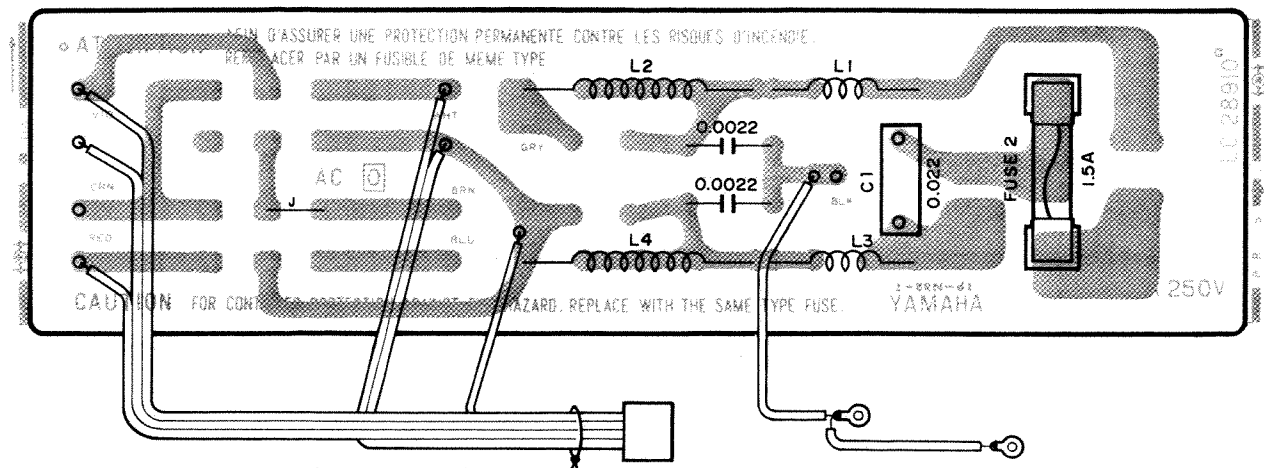

Pattern Side (パターン側)

• N. European model

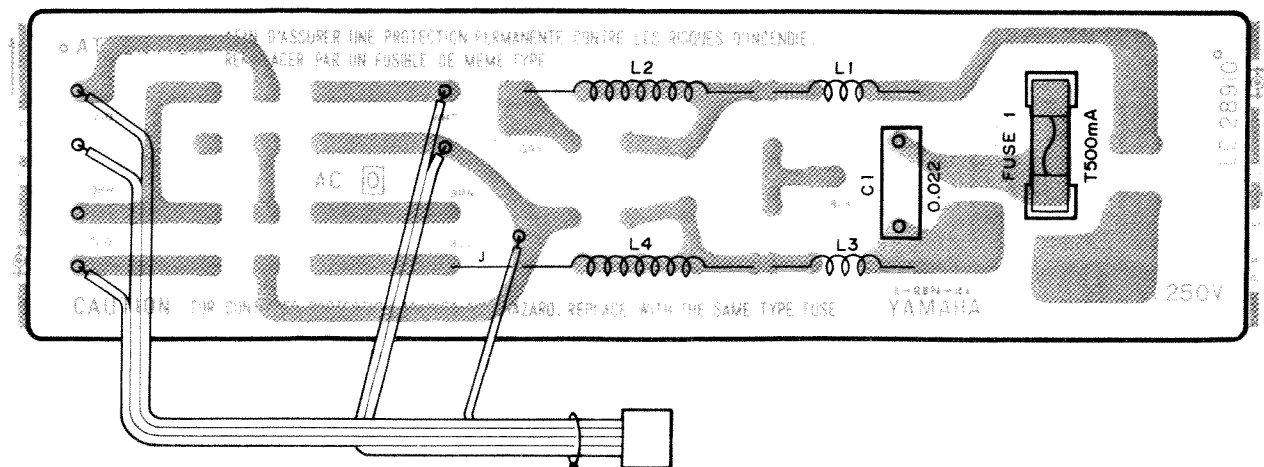

Pattern Side (パターン側)

KEP-NA10703-14 △

